

MODEL #00519

Intuit Sled Base Chair, 18"H

DESIGN:

The Intuit is our most ergonomic option with unmatched comfort and style. The shell is contoured for comfort in the seat and the back. The first cooperative learning chair. It's shape was derived purely as an invitation to come, sit and learn. Meanwhile, it's ample dimensions make students of all sizes comfortable throughout the day. The Intuit chair is the latest expression of furniture that contributes to a healthy, effective learning environment. The 18 inch option is for high school students and adults.

MATERIALS:

The shell is made from 100% virgin polypropylene with color through-out and a distinct texture to prevent slipping. The free flowing design of the Intuit comes from the innovative use of Gas Injection Technology. The integrated handle eases classroom positioning. The frame is constructed from 11-gauge 1 1/8" diameter steel tube, protected by a durable powder coat finish and is MIG-welded for maximum strength. The tubular frame supports the perimeter of the shell and incorporates a reinforcing crossbar for added strength. The shell is anchored securely to the frame through four 11-gauge die formed brackets, no rivets. The frame is supported by custom molded glides.

PRODUCT SPECIFICATIONS:

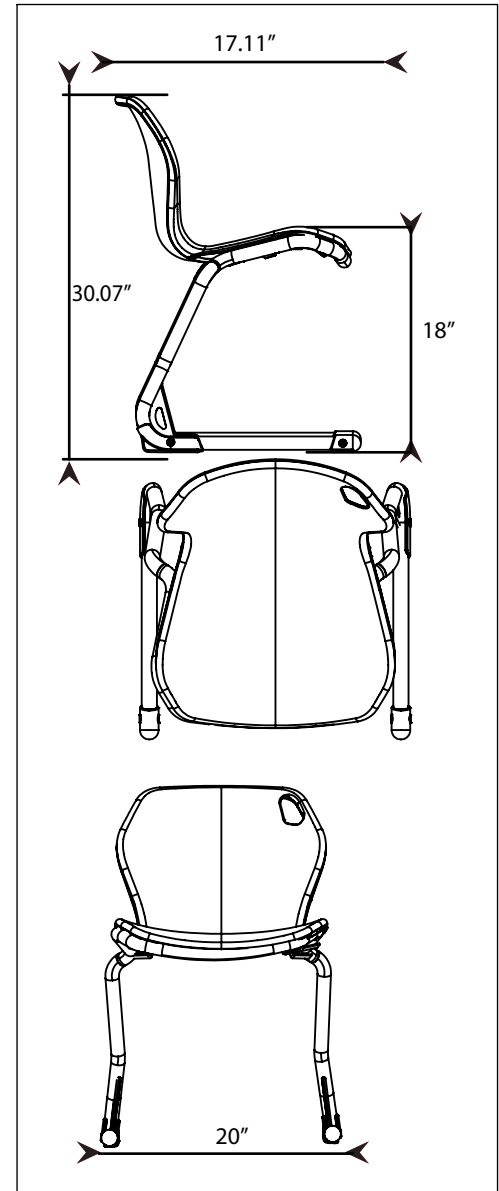

DIMENSIONS & FREIGHT: Product is UPSable.

Model	Description	D"	W"	H"	F.C.	Cube	Wt.
Intuit Sled Chair							
00519	Intuit Sled Base Chair - A Shell 18"	17	20	18	125	12	
	00519 Carton Dimensions	31.5	26	40			

F Felt glide option Set of 4 installed upcharge

Glide Options

Nylon base is standard. Optional is felt base:

*This is factory installed option not available for field installation. Glide option must be on original chair order.

Felt glide option : Add ' F ' to follow Model No.

AVAILABLE COLORS:

Intuit Frame Color Choice

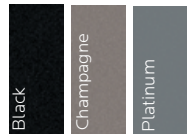

Intuit Shell Color Choice



WWW.SMITHSYSTEM.COM

