

MODEL #00530, 00531

Intuit Adjustable Chair (A+ Shell)

DESIGN:

The Intuit is our most ergonomic chair option with unmatched comfort and style. This adjustable chair allows you to move around freely and help to maintain support for your back, legs and arms as you change body positions. It's shape was purely derived as an invitation to come sit and learn. Meanwhile, it's ample dimensions makes students of all sizes comfortable throughout the day. The Intuit chair is the latest expression of furniture that contributes to a healthy, effective learning environment.

MATERIALS:

The shell is made from 100% virgin polypropylene with color throughout and a distinct texture to prevent slipping. The free flowing design of the Intuit comes from the innovative use of Gas Injection Technology. The integrated handle eases classroom positioning. The seat is secured to the frame with an 11 gauge plate mounted by 4 screws beneath the chair. The plate attaches to a pneumatic lift, which is a hydraulic cylinder that adjusts from 16" to 21" in height. The lift also allows a full 360 degree swivel. The base has a 28" diameter 5-star base for added stability. It comes with black nylon base and a choice of glides or 2" soft tread casters.

DIMENSIONS & FREIGHT:

Model	Description	D"	W"	H"	F.C.	Cube	Wt.	UPS
Intuit Adjustable Chairs								
00530	Intuit Adjustable (A+ Shell) - glides	28	28	16-21	85	2.1	29	✓
00531	Intuit Adjustable (A+ Shell) - casters	28	28	16-21	85	2.1	29	✓

PRODUCT SPECIFICATIONS:

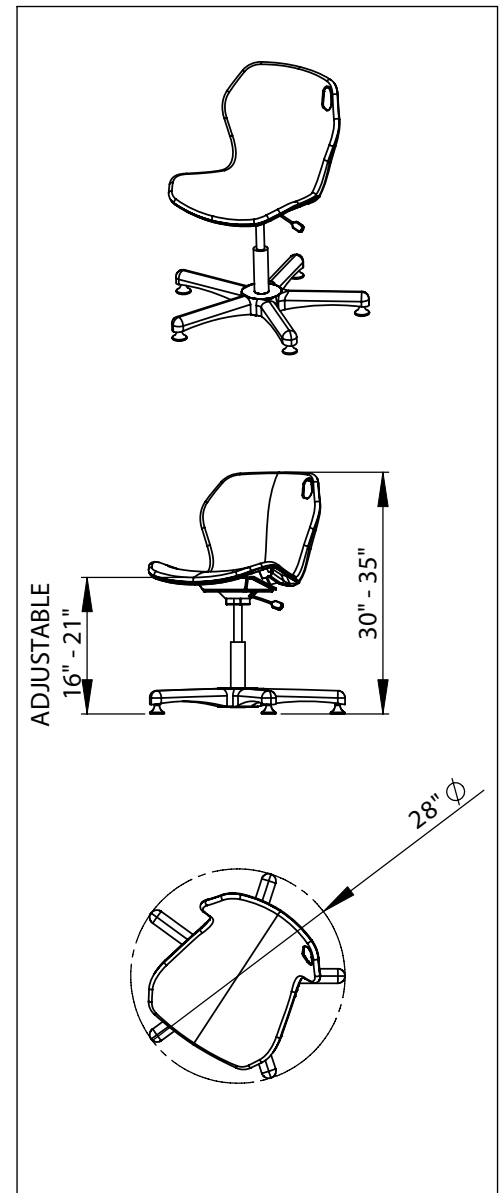

AVAILABLE COLORS:

Intuit Adjustable Chair Color Choice



5-Star Base

