

MODEL #01340

Flex Station 3-Student Trapezoid Work Center

DESIGN:

If laptop computers have made their way into your classroom, the Flex Station helps you create an optimal learning environment. Trapezoid Flex Tables permit unique classroom configurations for group learning. Use them separately to accommodate three students or place two together to create a hexagon work area.

MATERIALS:

The 1 1/4" thick work surface consists of a 45 lb. density particle board core with a .030" high pressure laminated surface and a .020" melamine backer sheet. The edge of the work surface features 3/8" bumper edge that is mechanically fastened every 6 to 8 inches to assure a long lasting fit. The top is pre-drilled for ease of installation.

The frame is attached to the pre-drilled holes in the top with (12) #10 x 3/4" screws through a 3 1/8" w x 22" l 14 gauge steel mounting plate. The mounting plate is welded to (2) 1" square 16 gauge steel Y-shaped tubes which is welded to a 1 1/4" x 2" 14 gauge vertical leg support. The legs adjust in height from 24" to 32" in 1" increments. The adjustment for each leg is secured with (2) 3 3/4" -16 x .675" Allen screws. All open ends on the 16 gauge tubing will be capped with color matched plastic end caps. The bases have a color matched lockable end cap/glide combination that resists tampering. The right and left leg both include Smith System patented backpack peg allowing for either inside or outside positioning. The 18-gauge steel wire management tray mounts under the work surface and hinges off the 10" h 16-gauge steel modesty panel. Cables drop through the work surface cut outs. Both the frame and legs will have a powder coat finish. With optional 3 or 4 inch casters. Also included is a cable basket tray in order to keep wiring and cables organized.

DIMENSIONS & FREIGHT:

Model	Description	D"	W"	H"	F.C.	Cube	Wt.	UPS
01340	Flex Station, 3-Student Trap Work Center	35	80	24-32	70	5.9	153	

PRODUCT SPECIFICATIONS:

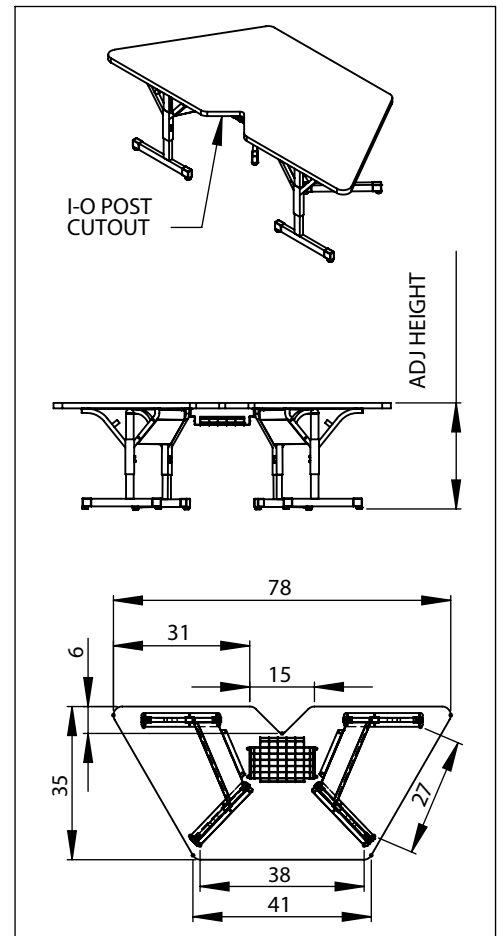

AVAILABLE COLORS:

Flex Station
Frame Color Choice



Flex Station Laminate Color Choice



Flex Station Edge Color Choice



Flex Stations Have Top and Edge Choices

1 1/4" Tops

3/8" Bumper T-Mold
CHOICE 1

4mm T-Mold
CHOICE 3

CHOICE 1 - 1 1/4" top with Bumper T-Mold no letter to follow Model No.

CHOICE 3 - 1 1/4" top with 4mm T-Mold D to follow Model No.



WWW.SMITHSYSTEM.COM

