

# MODEL #01354

## Flex Student Desk (20" x 48")

### DESIGN:

The Flex two-student desk has an oversized work surface that accommodates laptop computers for project learning environments.

### MATERIALS:

The 1 1/4" thick work surface consists of a 45 lb. density particle board core with a .030" high pressure laminated surface and a .020" melamine backer sheet. The edge of the work surface features bumper edge that is mechanically fastened every 6 to 8 inches to assure a long lasting fit. The top is pre-drilled for ease of installation. This versatile Flex Student Desk allows for a variety of arrangements in the classroom.

The frame is attached to the pre-drilled holes in the top with (12) #10 x 3/4" screws through a 3"w x 18"l 14 gauge steel mounting plate. The mounting plate is welded to (2) 1" square 16 gauge steel Y-shaped tubes which is welded to a 1 1/4" x 2" 14 gauge vertical leg support. The legs adjust in height from 24" to 32" in 1" increments. The adjustment for each leg is secured with (2) 3 3/4" -16 x .675" Allen screws. All open ends on the 16 gauge tubing will be capped with color matched plastic end caps. The bases have a color matched lockable end cap/glide combination that resists tampering. The right and left leg both include Smith System patented backpack peg allowing for either inside or outside positioning. The legs are tied together for added strength with a 1" x 2" 14 gauge steel crossbar that supplies a rigid long lasting piece of furniture.

### PRODUCT SPECIFICATIONS:

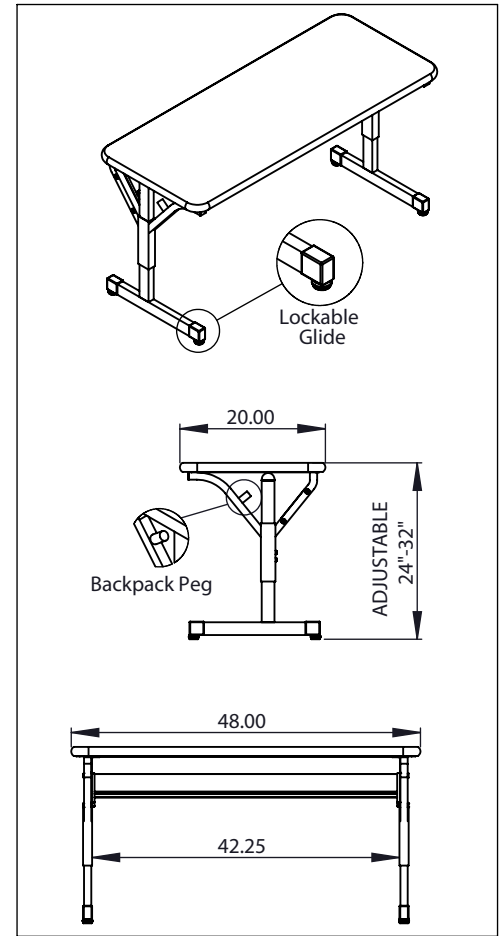

### DIMENSIONS & FREIGHT:

Model	Description	D"	W"	H"	F.C.	Cube	Wt.	UPS
20" Deep Two-Student Flex Desk								
01354	Flex Desk, Two-Student	20	48	24-32	70	4.1	61	✓
	Carton Dimensions	26.88	55.5	6.5				

### AVAILABLE COLORS:

Flex Desk  
Frame Color Choice

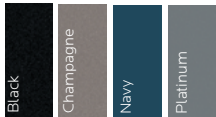

Flex Desk Laminate Color Choice



Flex Desk Edge Color Choice



**Flex Desks Have Top and Edge Choices**

**1 1/4" Tops**

- CHOICE 1** - 3/8" Bumper T-Mold
- CHOICE 2** - 3mm Edge
- CHOICE 3** - 4mm T-Mold

**3/4" Tops**

- CHOICE 4** - 3mm Edge
- CHOICE 5** - 4mm T-Mold
- CHOICE 6** - Bullet T-Mold

**CHOICE 1** - 1 1/4" top with Bumper T-Mold  
no letter to follow Model No.

**CHOICE 2** - 1 1/4" top with 3mm Edge  
F to follow Model No. Rectangle only.

**CHOICE 3** - 1 1/4" top with 4mm T-Mold  
D to follow Model No.

**CHOICE 4** - 3/4" top with 3mm Edge  
E to follow Model No. Rectangle only.

**CHOICE 5** - 3/4" top with 4mm T-Mold  
C to follow Model No.

**CHOICE 6** - 3/4" top with Bullet T-Mold  
V to follow Model No.



WWW.SMITHSYSTEM.COM

