

MODEL #01373

Flex Station (24" x 30")

DESIGN:

The Flex Station table is truly flexible, with an oversized top that provides for today's project learning environments.

MATERIALS:

The 1 1/4" thick work surface consists of a 45 lb. density particle board core with a .030" high pressure laminated surface and a .020" melamine backer sheet. The edge of the work surface features 3/8" bumper edge that is mechanically fastened every 6 to 8 inches to assure a long lasting fit. The top is pre-drilled for ease of installation.

The frame is attached to the pre-drilled holes in the top with (12) #10 x 3/4" screws through a 3" w x 18" l 14 gauge steel mounting plate. The mounting plate is welded to (2) 1" square 16 gauge steel Y-shaped tubes which is welded to a 1 1/4" x 2" 14 gauge vertical leg support. The legs adjust in height from 24" to 32" in 1" increments. The adjustment for each leg is secured with (2) 3 3/4" -16 x .675" Allen screws. All open ends on the 16 gauge tubing will be capped with color matched plastic end caps. The bases have a color matched lockable end cap/glide combination that resists tampering. The right and left leg both include Smith System patented backpack peg allowing for either inside or outside positioning. The 18-gauge steel wire management tray mounts under the work surface and hinges off the 10"h 16-gauge steel modesty panel. Cables drop through the work surface cut outs. Both the frame and legs will have a powder coat finish. With optional 3 or 4 inch casters.

PRODUCT SPECIFICATIONS:

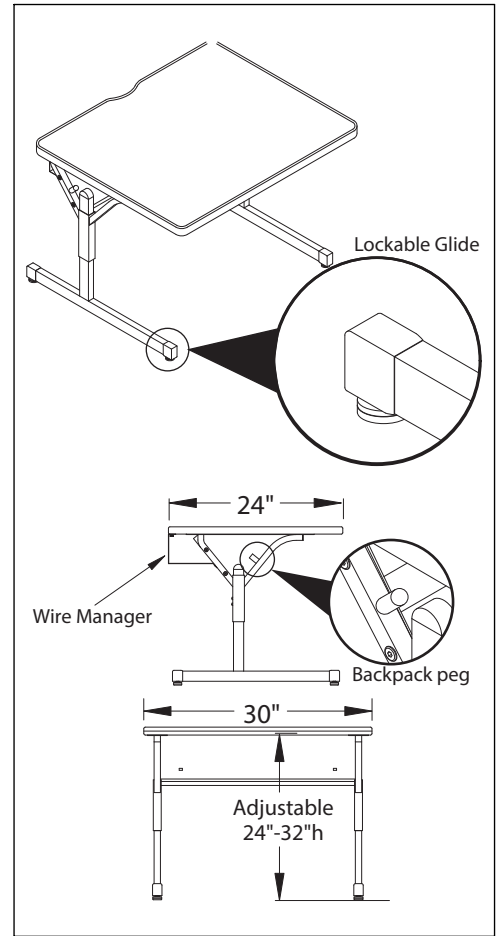

DIMENSIONS & FREIGHT:

Model	Description	D"	W"	H"	F.C.	Cube	Wt.	UPS
24" Deep Flex Station w/ Tilt Down Wire Manager								
01373	Flex Station w/ Tilt Down Wire Manager	24	30	24-32	70	3.3	65	✓
	Carton Dimensions	28	30	7				

AVAILABLE COLORS:

Flex Station
Frame Color Choice



Flex Station Laminate Color Choice



Flex Station Edge Color Choice

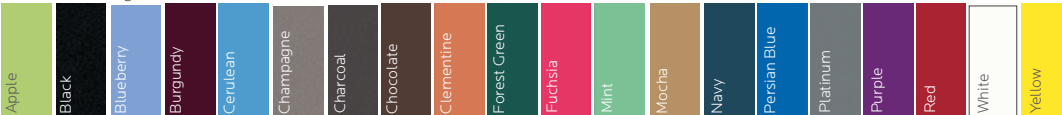

1 1/4" Tops

Flex Stations Have Top and Edge Choices

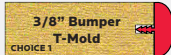

3/8" Bumper T-Mold
CHOICE 1



4mm T-Mold
CHOICE 3

CHOICE 1 - 1 1/4" top with Bumper T-Mold no letter to follow Model No.

CHOICE 3 - 1 1/4" top with 4mm T-Mold **D** to follow Model No.



WWW.SMITHSYSTEM.COM

