

# MODEL #11830, 11831, 11840, 11841

## Flavors Adjustable Chair

### DESIGN:

Offering an adjustable chair and stool version of Flavors Seating was a must. After all, when you combine the little bit of flex in the back of the chair together with the ability to custom fit the chair height, the result is a very comfortable chair. It's a great option use in computer labs, art rooms and offices.

### MATERIALS:

The shell is 100% virgin polypropylene material with a shallow seat pan allowing four-position seating for infinite sitting styles. The back supplies rigid support while being specifically designed with added flexibility that adapts to individual requirements and supplies long lasting comfort. The shell includes an integrated handle molded in for easy movement of the chair. The seat is secured to the frame with an 11 gauge plate mounted by 4 screws beneath the chair. The plate attaches to a pneumatic lift, which is a hydraulic cylinder that allows a full 360 degrees swivel. It comes with a black nylon base with a 28.5" diameter 5-star design and in a choice of glides or 2" soft tread casters.

### DIMENSIONS & FREIGHT:

Model	Description	D"	W"	H"	F.C.	Cube	Wt.	UPS
Flavors Adjustable Chairs								
11840	Flavors Adjustable (A Shell) - casters	28	28	16-21	85	2.1	26	✓
11841	Flavors Adjustable (A Shell) - glides	28	28	16-21	85	2.1	26	✓
11830	Flavors Adjustable (B Shell) - casters	26	26	14-18	85	2.1	26	✓
11831	Flavors Adjustable (B Shell) - glides	26	26	14-18	85	2.1	26	✓

### PRODUCT SPECIFICATIONS:

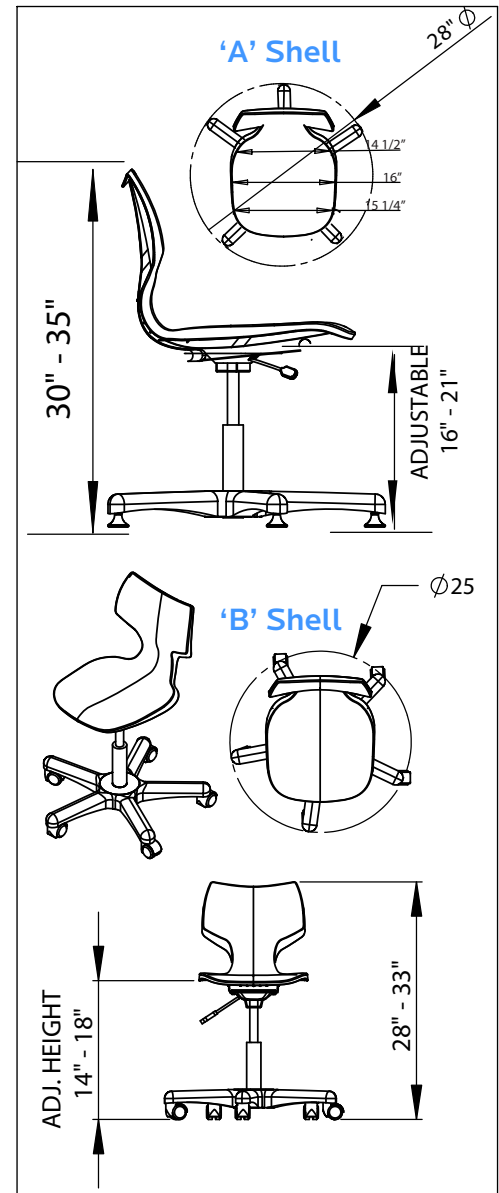

### AVAILABLE COLORS:

Flavors Adjustable Chair Color Choice

