

# MODEL #21031

## Four Sloping Shelves, Top Flat Shelf Truck

### DESIGN:

Smith System™ Book Trucks are a handy companion to the library or classroom, carrying up to 400 lb of books, paper and projects. They move easily through aisles on soft-tread, dual wheel casters that won't shimmy like single wheels.

### MATERIALS:

Smith System™ Book Truck #21031 consists of (2) Frames, (2) End Panels, and (2) Sloping Shelf Weldments and (1) Flat Shelf. The End Panels consist of 20-gauge steel full height panels welded to 1" square 18-gauge steel tubing Frame with formed in handles that radius for added comfort and ease of movement. The Sloping Shelves are constructed of 20-gauge steel double sided sloping shelves that are 34" long and 7 3/4" deep on each side and 6" high back. The Flat Shelf is constructed of 20-gauge steel that is 34" long x 17 9/16" deep x 1" high edge. The shelves sport a 12 3/4" clearance between shelves and are welded to the frames and end panels of the Book Truck. All Book Trucks feature 4" diameter dual wheel casters with soft tread for quiet operation. Dual wheels have no saddle that may damage surrounding furniture.

### DIMENSIONS & FREIGHT:

Model	Description	D"	W"	H"	F.C.	Cube	Wt.	UPS
21031	4 Sloping, Top Flat Truck	18	36	43	150		71	
	21031 Carton	19	37½	40	150			

### PRODUCT SPECIFICATIONS:

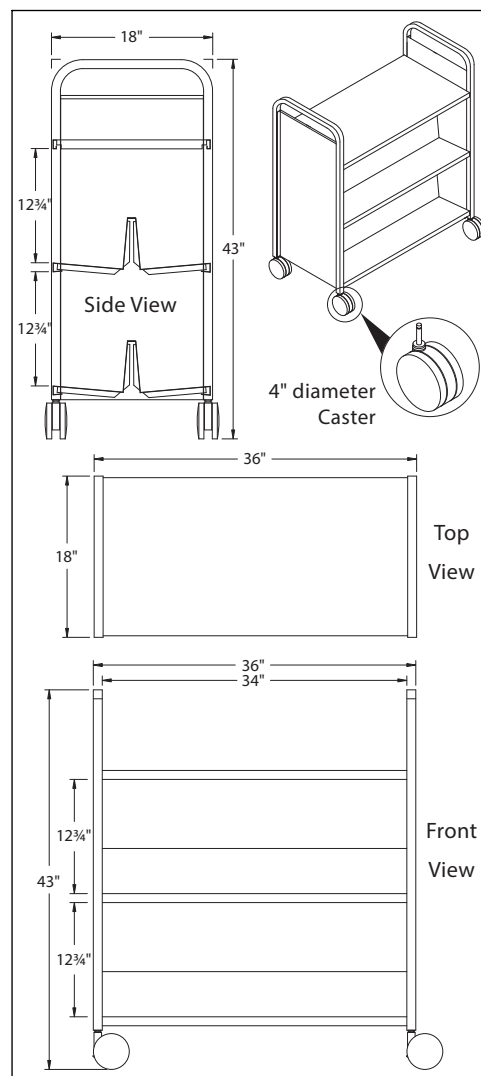

### AVAILABLE COLORS:

#### Booktruck Color Choices

