

MODEL #21091

Two Flat Shelf Truck

(2 Flat Shelf Truck)

DESIGN:

Smith System™ Book Trucks are a handy companion to the library or classroom, carrying up to 400 lb of books, paper and projects. They move easily through aisles on soft-tread, dual wheel casters that won't shimmy like single wheels.

MATERIALS:

Smith System™ Book Truck #21091 consists of (2) Frames, (2) End Panels and (2) Flat Shelves. The End Panels consist of 20-gauge steel full height panels welded to 1" square 18-gauge steel tubing Frame with formed in handles that radius for added comfort and ease of movement. The Shelves are constructed of 20-gauge steel that are 34" long x 17 9/16" deep and 1" high edge. The shelves sport a 16 1/2" clearance between shelves and are welded to the frames and end panels of the Book Truck. All Book Trucks feature 4" diameter dual wheel casters with soft tread for quiet operation. Dual wheels have no saddle that may damage surrounding furniture.

PRODUCT SPECIFICATIONS:

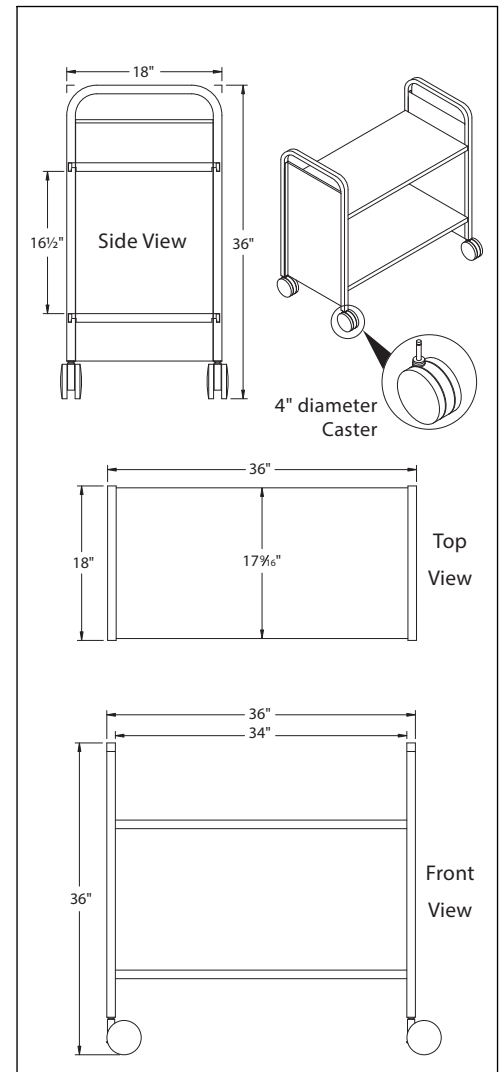

DIMENSIONS & FREIGHT:

Model	Description	D"	W"	H"	F.C.	Cube	Wt.	UPS
21091	Buffalo Book Truck (2 Shelf)	18	36	36	150		42	
	21091 Carton	19	37 1/2	34	150			

AVAILABLE COLORS:

Booktruck Color Choices



WWW.SMITHSYSTEM.COM

