

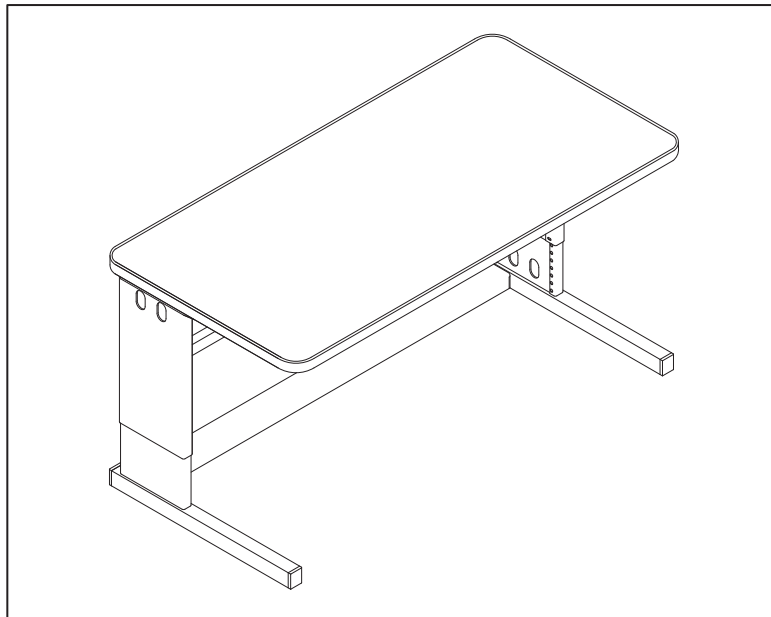

Circulation Desk™

Assembly Instructions
for the following workstations:



Bullet
Rectangle
Peninsula
Contour

Form# 179863



For assistance in assembling product, missing or damaged parts, or to place an order please contact customer service at 800-328-1061. You may also place your order online at

www.smithsystem.com

Special Notes

1. Check that all components are accounted for and undamaged before assembling.
2. Please assemble product in a clean and dry area.
3. For larger units you may need another person to help assemble the product.
4. Clean the product with a mild cleaner and a damp cloth.

Tools

You will need a Phillips head screw driver.

Notes:

If you have damaged or missing components or hardware please contact customer service at (800) 328-1061

Hardware and Components

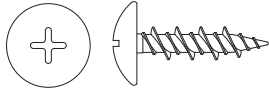

Wood Screws (13)*

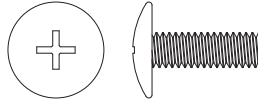

10-32x1/2" Machine Screws (4)*

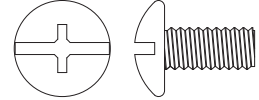

1/4-20x1/2" Machine Screws (12)*

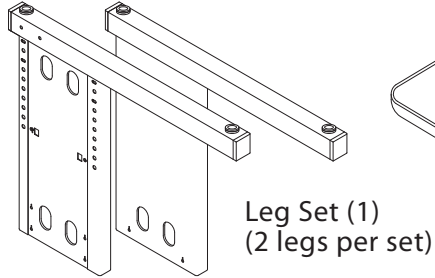

Leg Set (1)
(2 legs per set)

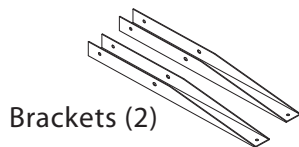

Brackets (2)

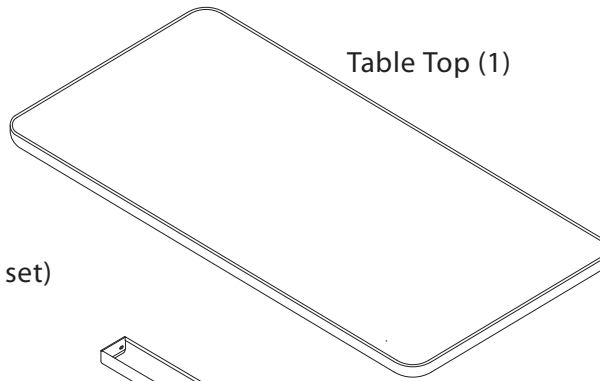
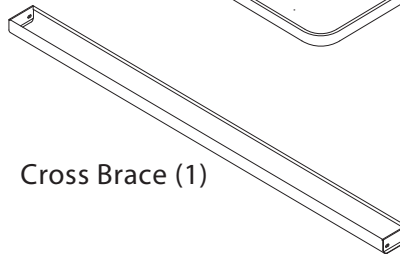
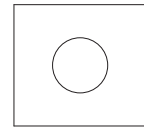

Table Top (1)



Cross Brace (1)



Tinnerman Clips (4)

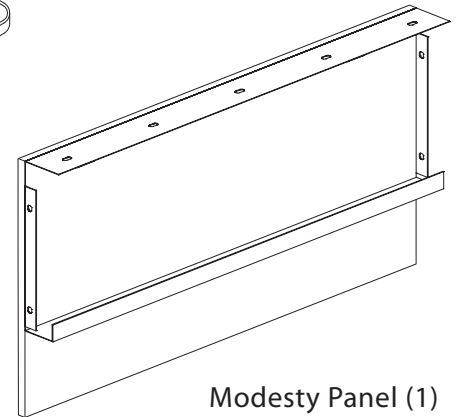

Modesty Panel (1)

*Our Cirucation Workstations come in different length and shapes, so hardware and screw hole placement will vary. If you feel you have not received all the hardware necessary, please call us at 800-328-1061.

Shapes And Sizes



Bullet Desk

Left or Right Handed
30"d
30"w, or 72"w



Rectangle Desk

30"d
36"w, or 48"w, 60"w, or 72"w



Peninsula Desk

Left or Right Handed
36"d
60"w, 72"w



Contour Desk

36"d
60"w, 72"w

Questions? Call Us.

800-328-1061

Assembly Instructions for Circulation Workstation

Step 1 Locate all the parts needed for assembly. Place the table top face down on a clean, dry surface. Attach the brackets to the top using the (8) wood screws and a phillips head screw driver. (See Drawing 1A). Next attach the legs to the brackets using (8) Machine Screws, (4) per leg. (See Drawing 1B).

Note: For left and right hand peninsula, and bullets. Verify the layout and pick your hole pattern.

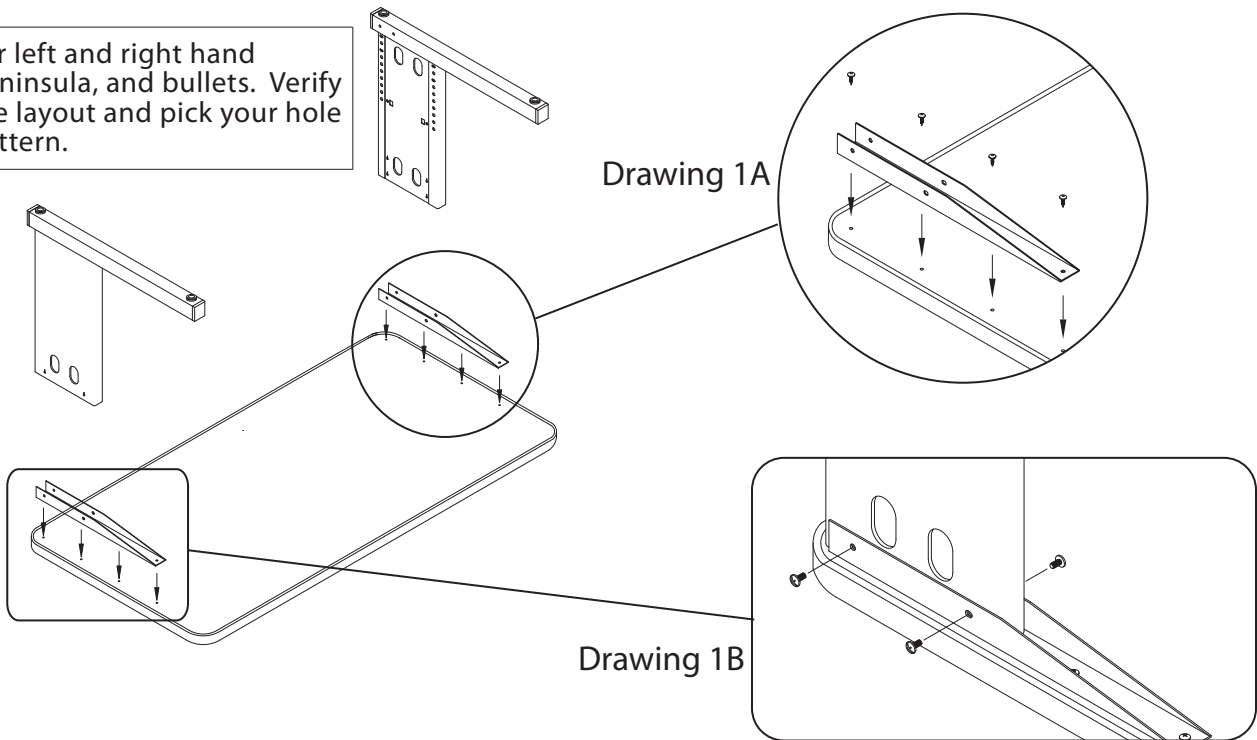

Step 2 Now adjust the legs to the desired height. (See Drawing 2). Drawing 2B shows the side view of what the exact length the leg needs to be set at.

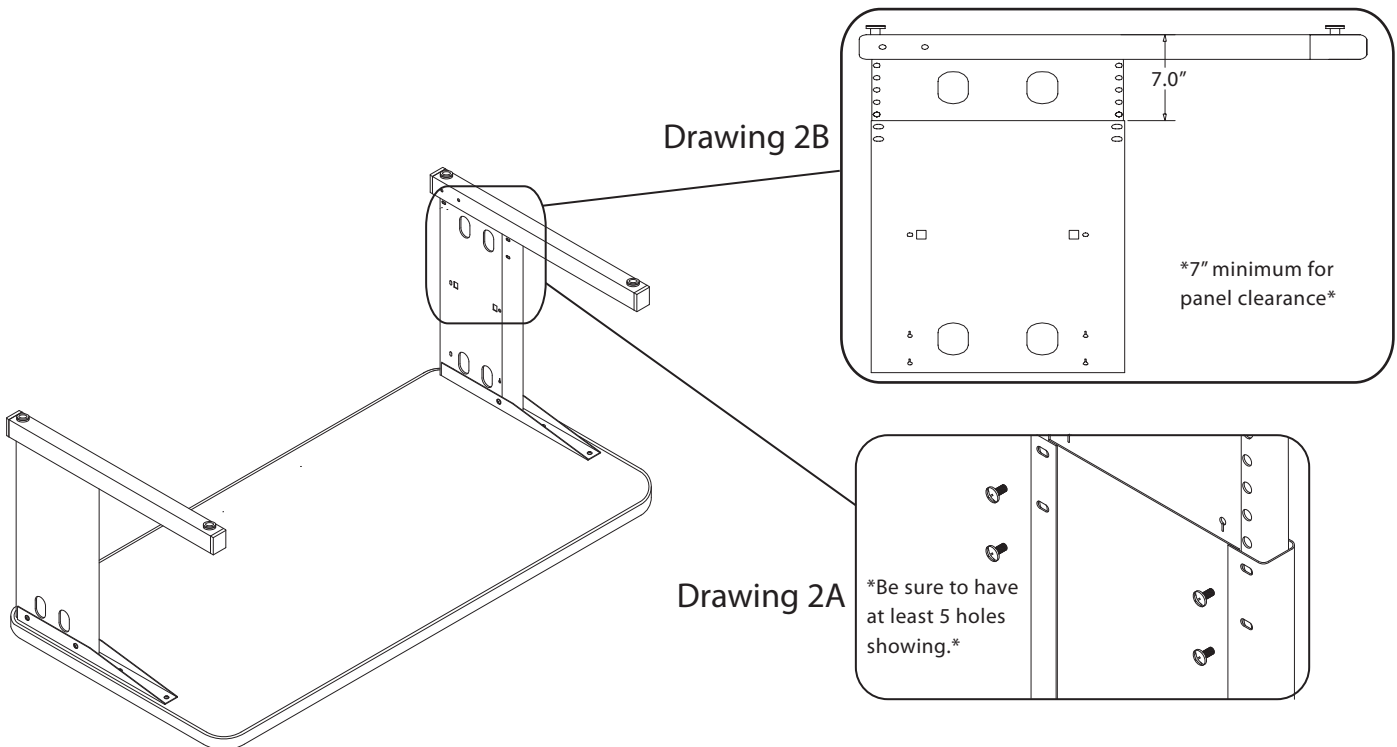

Assembly Instructions for Acrobat Workstation

Step 3 Now install (1) Tinnerman Clip per leg, in square hole located inside of the leg. (See Drawing 3A)

NOTE: Tinnerman clip only used if desk is raised to high range, when set to low range threaded hole from lower leg will be used instead of tinnerman clip.

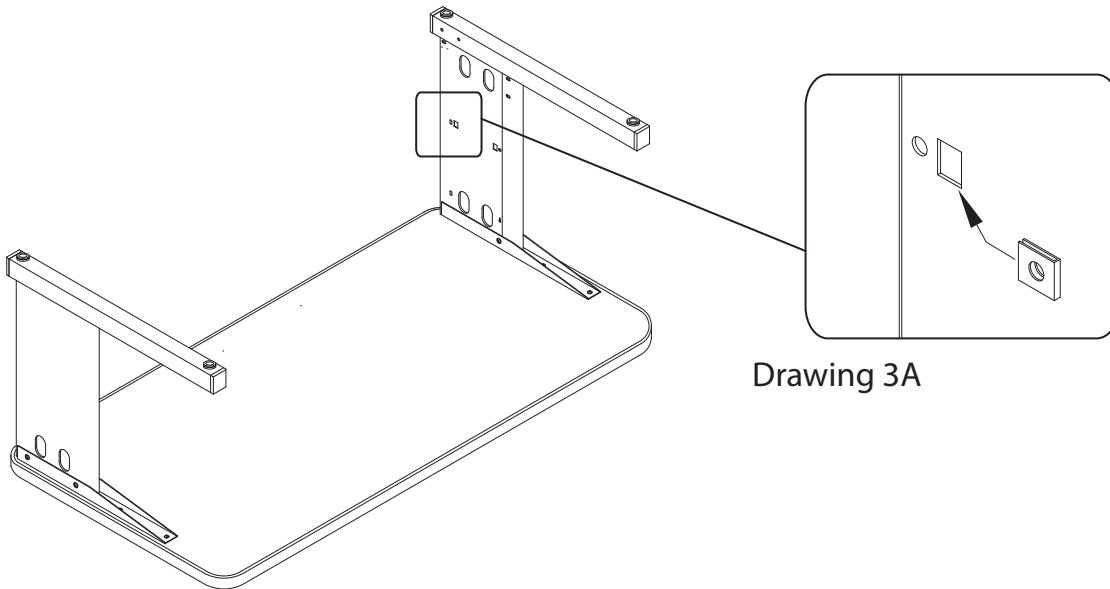

Step 4 Once the legs are secure, loosely attach the modesty panel to the legs using (4) Machine Screws. (See Drawing 4A). Now use the remaining wood screws to attach the modesty panel to the table top. (See Drawing 4B). Once all screws are in go back and tighten screws on the legs.

NOTE: Legs must be adjusted to desired height range before installing modesty panel.

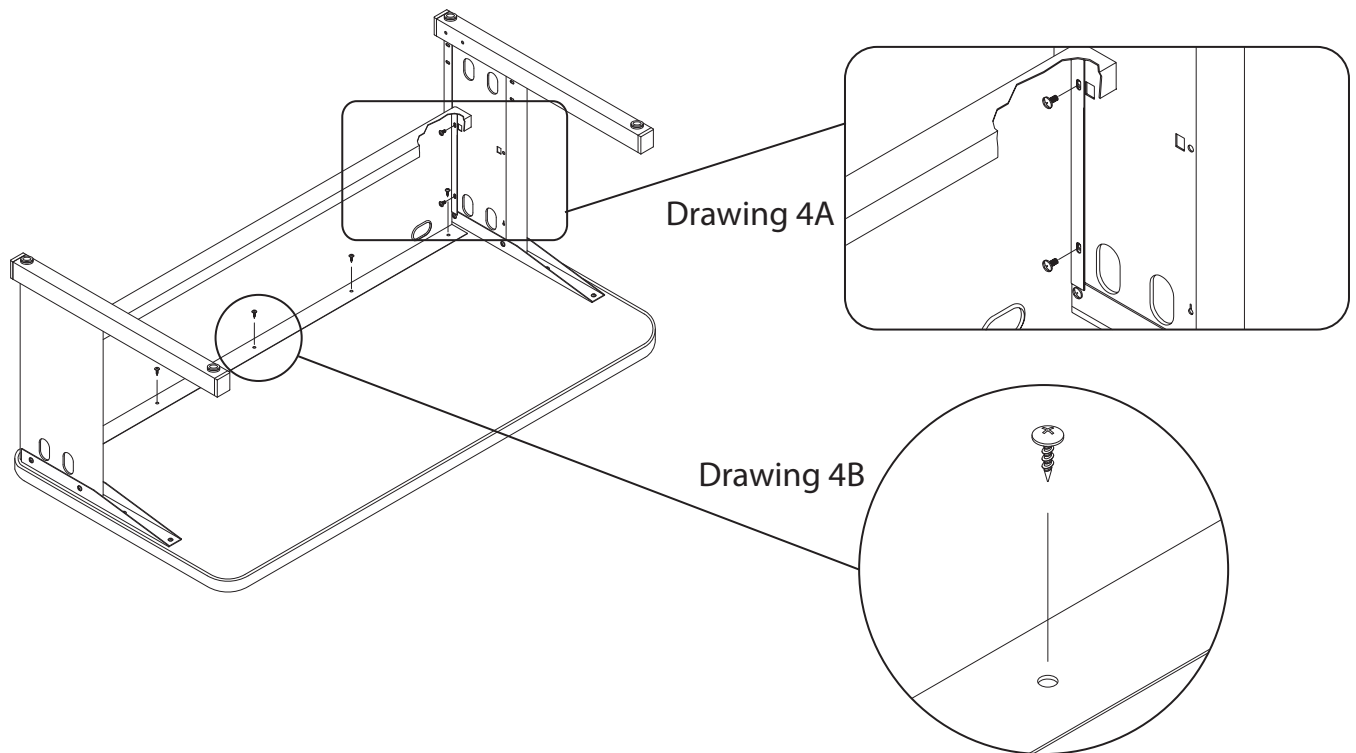

If you have any questions
contact customer service.

800-328-1061

www.smithsystem.com

Assembly Directions for a Circulation Workstation

Step 5 Attach the cross bar to the foot of the legs using (4) 10-32X1/2" Machine Screws. (See Drawing 5A).

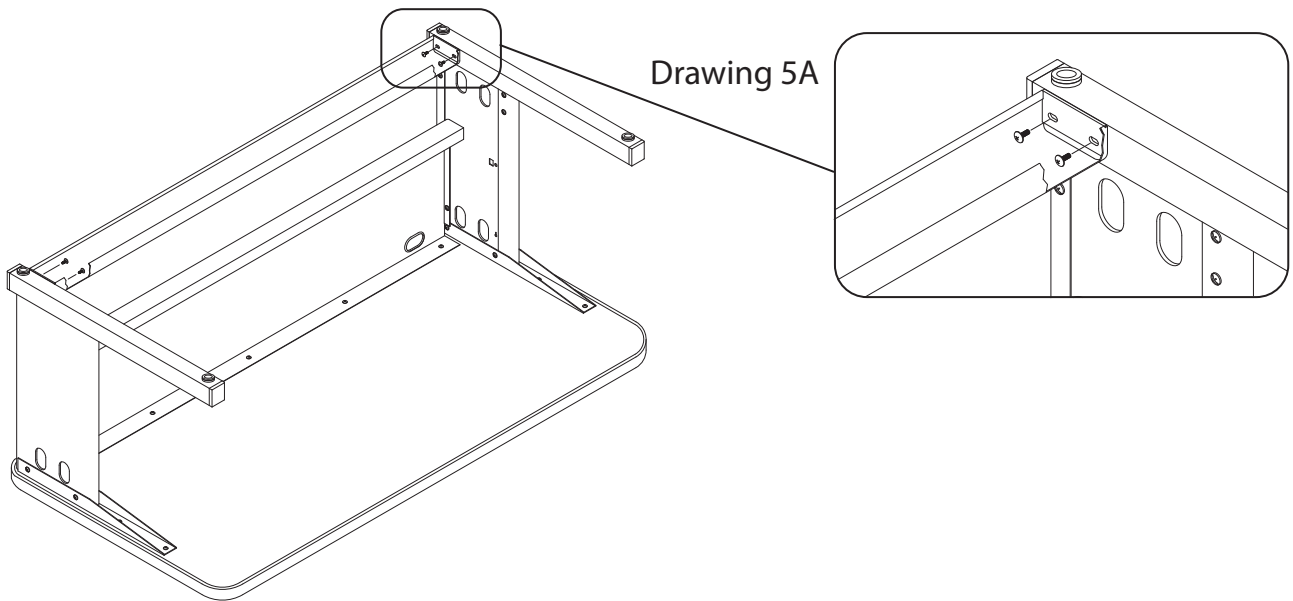

Step 6 With help, tip the desk in the upright position. Your desk is ready for use.

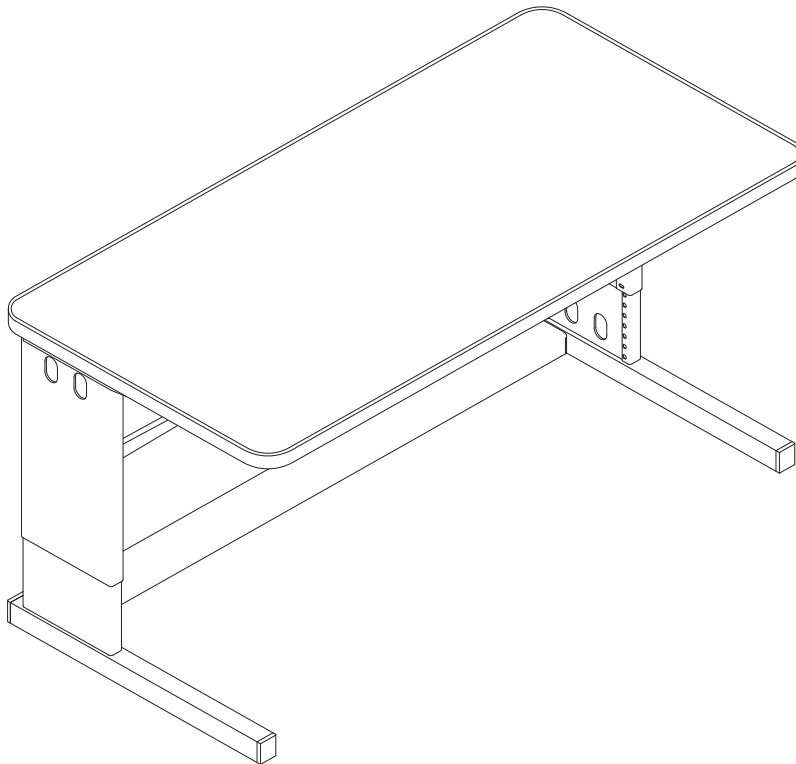

If you have any questions
contact customer service.

800-328-1061

www.smithsystem.com