



## 6 Drawer Cabinet

### Model# 09350

The 6 drawer cabinet has welded steel construction with rounded arc handles. Drawers have rubber pads that allow frictionless movement across the glide rail. Shipped assembled.

Qty: \_\_\_\_\_

Color: \_\_\_\_\_

## Material

The drawer ped is made out of durable metal, yet light weight for easy movement. The spacious file drawers are 14"w x 17<sup>3</sup>/<sub>4</sub>"D. The unit comes with 12 keys, each drawer is individually locked.

## Dimensions

Product dimensions: 22"d x 15 <sup>7</sup>/<sub>8</sub>"w x 22"h

## Available Colors

Black

Champagne

Sand

## Freight

Weight: 54 lbs.

Freight Class: 125

Product is NOT UPSable

## Product Specifications

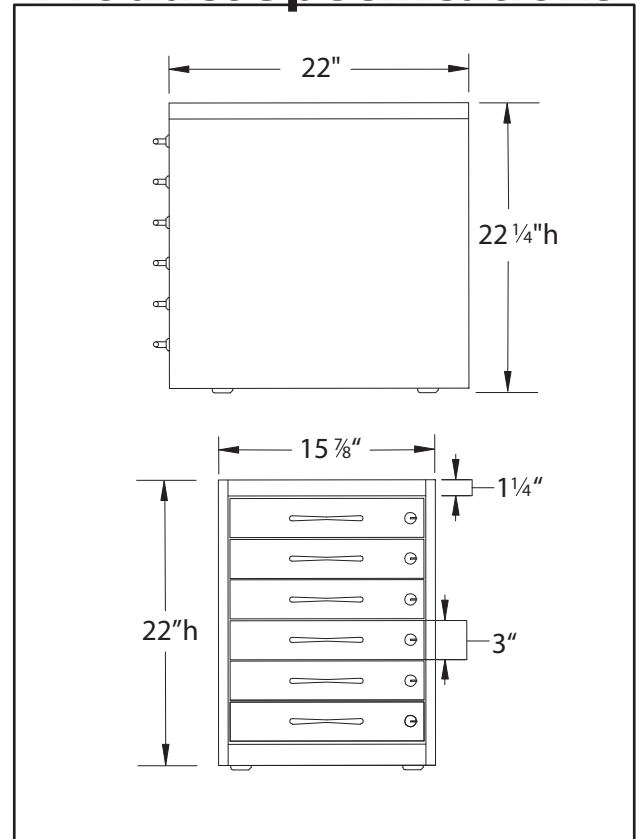

For more information call 1-800-328-1061 or email: [furniture@smithsystem.com](mailto:furniture@smithsystem.com)

