

Buffalo Book Truck

Model# 21091 (2) Flat Shelf Truck

Buffalo Book Trucks are a handy companion to the library or classroom, carrying up to 400 lbs. of books, paper, and projects. They move easily through aisles on soft-tread, dual wheel casters that won't shimmy like single wheels.

Qty: _____

Color: _____

Material

This Buffalo Book Truck consists of (2) Frames, (2) End Panels, and (2) Flat Shelves. The **End Panels** consist of 20-gauge steel full height panels welded to 1" square 18-gauge steel tubing **Frame** with formed in handles that radius for added comfort and ease of movement. The **Shelves** are constructed of 20-gauge steel that are 34" long x 17 $\frac{5}{16}$ " deep x 1" high edge. The shelves sport a 16 $\frac{1}{2}$ " clearance between shelves and are welded to the frames and end panels of the Book Truck. All Book Trucks feature 4" diameter dual wheel casters with soft tread for quiet operation. Dual wheels have no saddle that may damage surrounding furniture.

Dimensions

Product dimensions: 18"d x 36"w x 36"h

Box dimensions: 19"d x 37 $\frac{1}{2}$ "w x 34"h

Freight Available Colors

Weight: 42 lbs.

Freight Class: 150

-Apple	-Mint
-Black	-Mocha
-Blueberry	-Navy
-Burgundy	-Persian Blue
-Cerulean	-Platinum
-Champagne	-Purple
-Chocolate	-Red
-Clementine	-Sand
-Forest Green	-Yellow
-Fuchsia	

Product Specifications

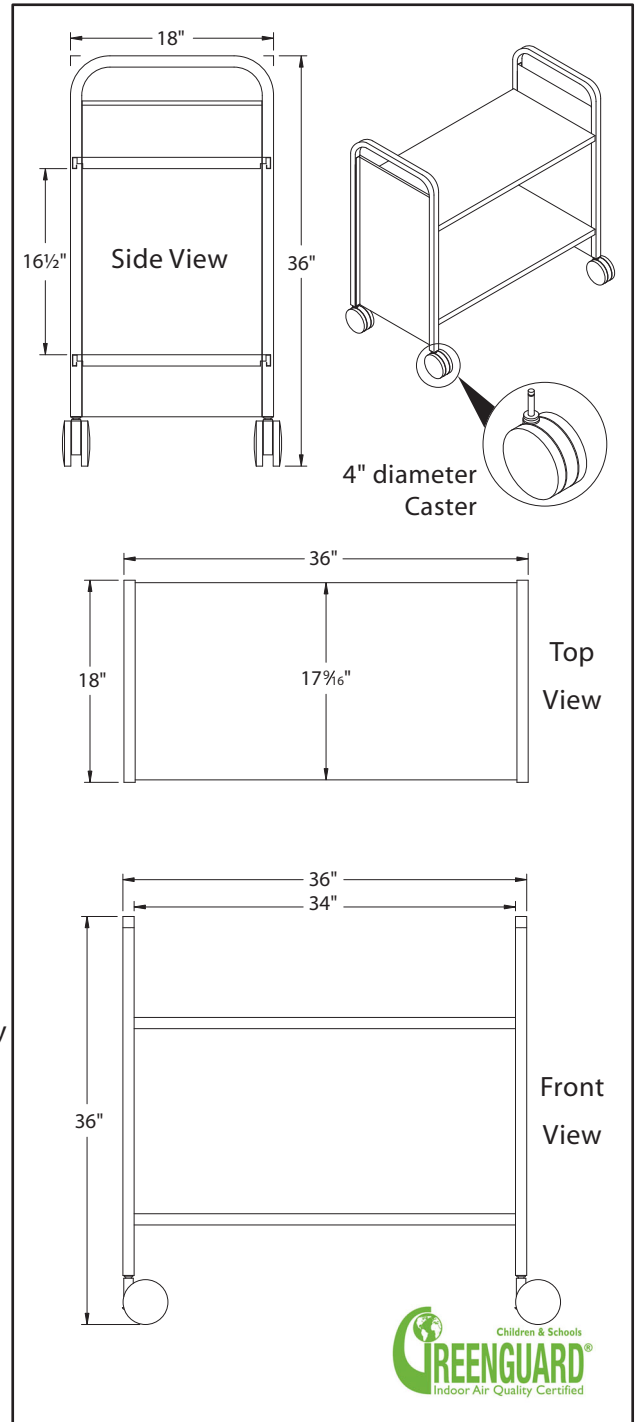

For more information call 1-800-328-1061 or email: furniture@smithsystem.com