

Gorilla Book Truck

Model# 21101 (6) Sloping Shelf Truck

Gorilla Book Trucks are a handy companion to the library or classroom, carrying up to 600 lbs. of books, paper, and projects. Fixed middle casters make it easy for the truck to pivot on an axis which makes it great for getting over thresholds. Comes standard with dual wheel casters that won't shimmy like single wheel casters.

Qty: _____

Color: _____

Material

Units come fully welded and assembled, just pop in the casters and they are ready to go. This Gorilla book truck consists of (2) Frames, (2) End Panels, and (3) Sloping Shelf Weldments. The **End Panels** consist of 20-gauge steel full height panels welded to 1" square 18-gauge steel tubing **Frame** with formed in handles that radius for added comfort and ease of movement. The **Shelves** are constructed of 20-gauge steel double sided sloping shelves that are 34" long x 7 $\frac{3}{4}$ " deep on each side and a 6" high back. The shelves sport a 12 $\frac{3}{4}$ " clearance between shelves and are welded to the frames and end panels of the Book Truck. Gorilla Book Trucks feature 5" diameter dual wheel casters with soft tread, which also includes a six-wheel construction for easy maneuverability. Dual wheels have no saddle that may damage surrounding furniture.

Dimensions

Product dimensions: 18"d x 36"w x 44"h

Box dimensions: 19"d x 37 $\frac{1}{2}$ "w x 40"h

Available Colors

-Apple	-Mint
-Black	-Mocha
-Blueberry	-Navy
-Burgundy	-Persian Blue
-Cerulean	-Platinum
-Champagne	-Purple
-Chocolate	-Red
-Clementine	-Sand
-Forest Green	-Yellow
-Fuchsia	

Freight

Weight: 89 lbs.

Freight Class: 150

Product Specifications

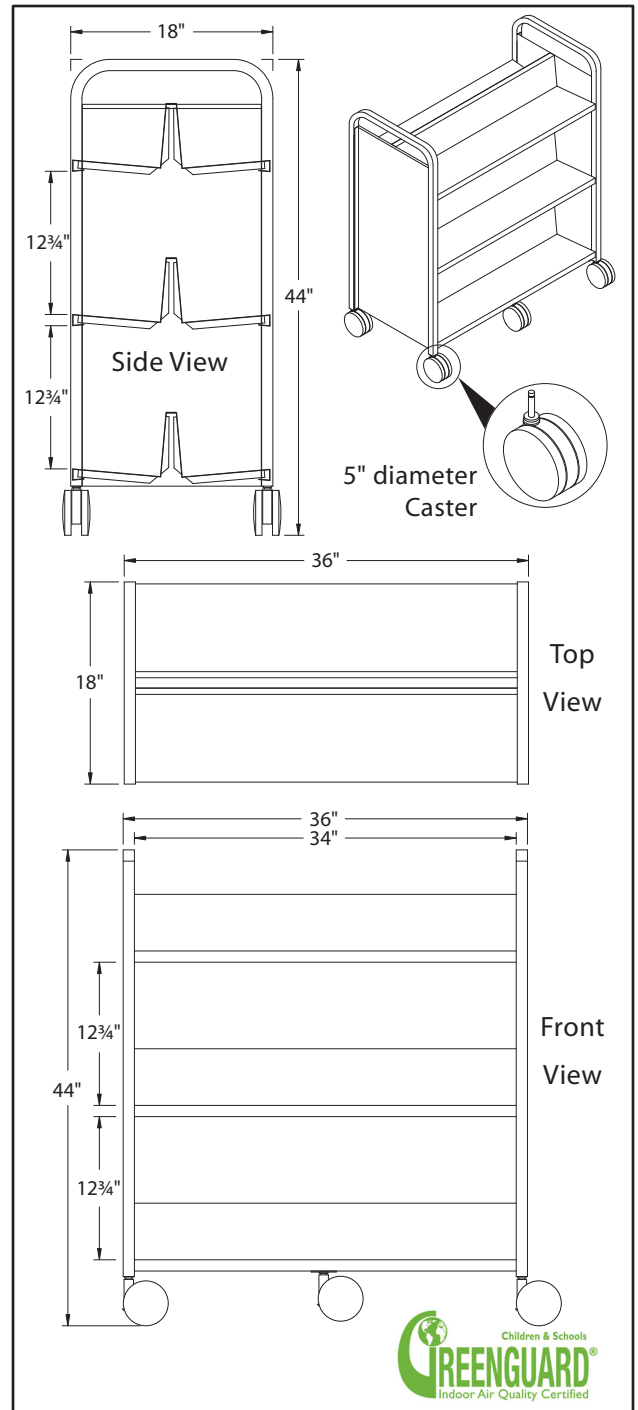

For more information call 1-800-328-1061 or email: furniture@smithsystem.com

