

30" d Acrobat Workstations

Model# 26423, 26433, 26443, 26453 & 26526 Rectangle

The strong, stable Acrobat Workstations can be used separately or in multiple combinations. It features a built-in wire raceway in the modesty panel for cable management.

Qty: _____

Color: _____

Material

The 1 ¼" thick work surface consists of a 45 lb. density particle board core with a .030 high-pressure laminated surface and a .020" melamine backer sheet. The edge of the work surface features ¾" bumper edge molding that is mechanically fastened every 6 to 8 inches to assure a long lasting fit. The top is pre-drilled for ease of installation.

The **Legs:** Telescoping leg allows height adjustment from 24 ½" to 36 ½". 1 ⅝" w x 10" d double wall panel legs of 12-, 14- and 18-gauge steel with rounded edges. Cable ports in upper leg for networking station to station and in lower leg for routing to floor. Base is 16-gauge steel tube 1 ¾" x 2" nylon caps to protect feet. Legs have 1" adjusting leveling glides.

The **Panel:** Modesty panel made from 18-gauge steel panel has built in raceway and cable ports in upper corners. Panel connects to work surface and legs. Acrobat workstations can go mobile with optional 3" or 4" dual wheel casters.

Freight

Weight: 26423 = 88 lbs.	26433 = 95 lbs.
26443 = 110 lbs.	26453 = 125 lbs.
26526 = 140 lbs.	

Freight Class: 70

*Product is UPSable

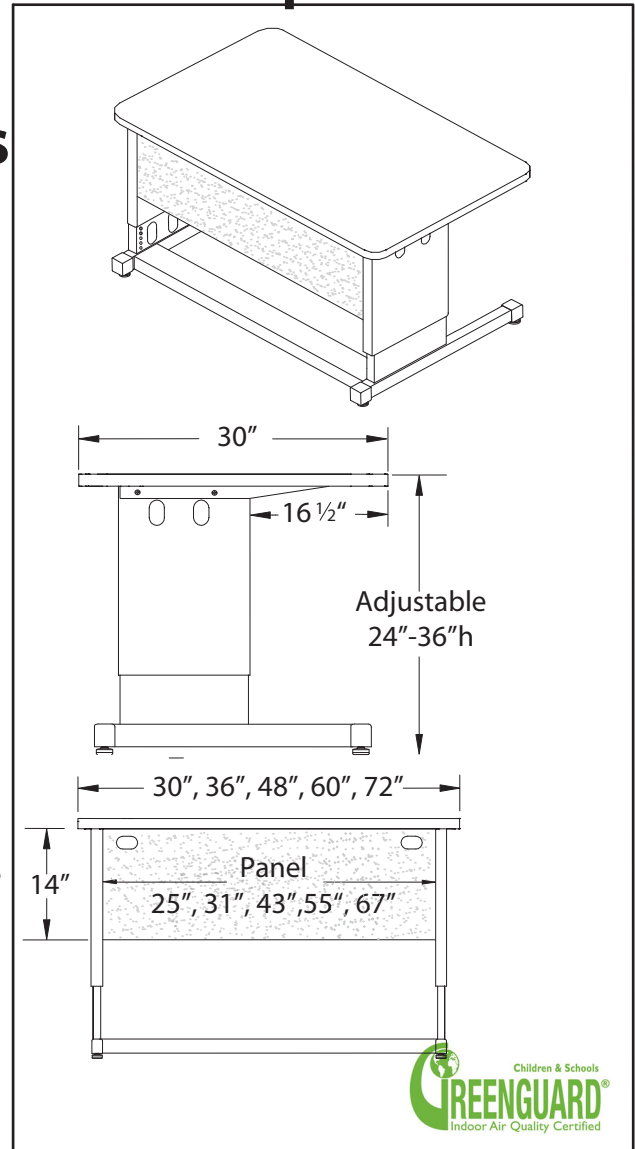

For more information call 1-800-328-1061 or email: furniture@smithsystem.com

Dimensions

Product dimensions: * 26423 = 30" d x 30" w x 24-36" h
 * 26433 = 30" d x 36" w x 24-36" h
 26443 = 30" d x 48" w x 24-36" h
 26453 = 30" d x 60" w x 24-36" h
 26526 = 30" d x 72" w x 24-36" h

Carton dimensions: 26423 = 30" d x 30" w x 3" h
 26433 = 31 ⅝" d x 36 ¼" w x 3 ⅝" h
 26443 = 31 ⅝" d x 51 ¼" w x 3 ⅝" h
 26453 = 31 ⅝" d x 63" w x 3 ⅝" h
 26526 = 31 ⅝" d x 75 ¼" w x 3 ⅝" h

Available Colors

Laminate Colors:

Amber Cherry, Blond Echo, Fusion Maple, Golden Oak, Grey Mesh, Grey Nebula, New Age Oak, Pewter Mesh, Tan Echo, Wild Cherry.

(Smith System is proud to offer any Wilsonart 60 Series laminate at no up charge for orders of 20 or more)

Edge Colors:

Apple, Black, Blueberry, Burgundy, Cerulean, Champagne, Charcoal, Chocolate, Clementine, Forest Green, Fuchsia, Mint, Mocha, Navy, Persian Blue, Platinum, Purple, Red, White, Yellow.

Frame Colors:

Black, Champagne, Chocolate, Platinum or Navy.