



# Product Specifications

## Acrobat Workstations

### Model# 26492, 26493, 26494 Corner

The strong, stable Acrobat Workstations can be used separately or in combinations and configurations. It features a built-in wire raceway in the modesty panel for cable management.

Qty: \_\_\_\_\_

Color: \_\_\_\_\_

## Material

The 1¼" thick work surface consists of a 45 lb. density particle board core with a .030 high-pressure laminated surface and a .020" melamine backer sheet. The edge of the work surface features ⅜" bumper edge molding that is mechanically fastened every 6 to 8 inches to assure a long lasting fit. The top is pre-drilled for ease of installation.

The **Legs**: Telescoping leg allows height adjustment from 24½" to 36½". 1⅝" w x 10" d double wall panel legs of 12-, 14- and 18-gauge steel with rounded edges. Cable ports in upper leg for networking station to station and in lower leg for routing to floor. Base is 16-gauge steel tube 1¾" x 2" nylon caps to protect feet. Legs have 1" adjusting leveling glides.

The (2) **Modesty Panels**: Are made from 18-gauge steel that has built in raceway and cable ports in upper corners. Panel connects to work surface and legs. Acrobat workstations can go mobile with optional 3" or 4" dual wheel casters.

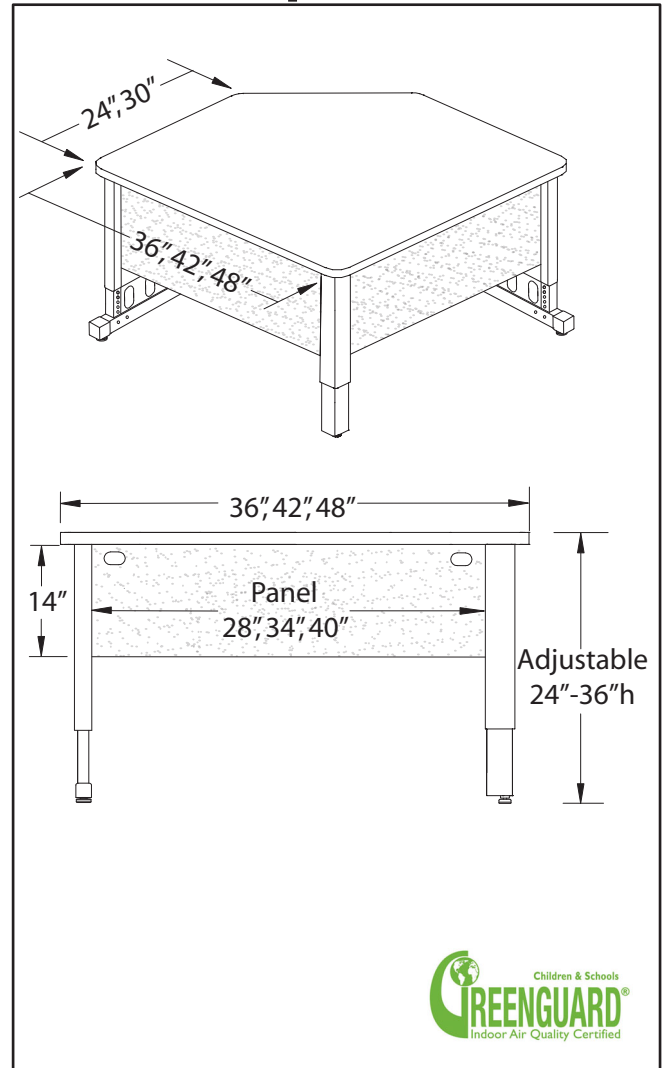

For more information call 1-800-328-1061 or email: [furniture@smithsystem.com](mailto:furniture@smithsystem.com)

## Dimensions

Product dimensions: 26492 = 30"d x 48"w x 24"-36"h  
 26493 = 24"d x 42"w x 24-36"h  
 26494 = 24"d x 36"w x 24-36"h

## Freight

Weight: 26492 = 148 lbs.  
 26493 = 127 lbs.  
 26494 = 106 lbs.  
 Freight Class: 70  
 Product is NOT UPSable

## Available Colors

### Laminate Colors:

Amber Cherry, Blond Echo, Fusion Maple, Golden Oak, Grey Mesh, Grey Nebula, New Age Oak, Pewter Mesh, Tan Echo, Wild Cherry.

(Smith System is proud to offer any Wilsonart 60 Series laminate at no up charge for orders of 20 or more)

### Edge Colors:

Apple, Black, Blueberry, Burgundy, Cerulean, Champagne, Charcoal, Chocolate, Clementine, Forest Green, Fuchsia, Mint, Mocha, Navy, Persian Blue, Platinum, Purple, Red, White, Yellow.

### Frame Colors:

Black, Champagne, Chocolate, Platinum or Navy.