

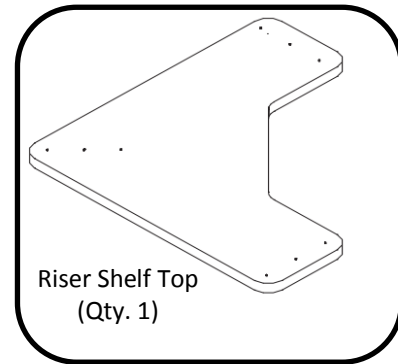

Acrobat Corner Riser Shelf

Hardware and Components

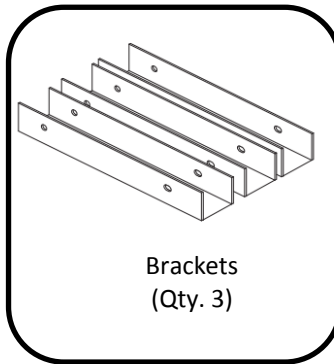
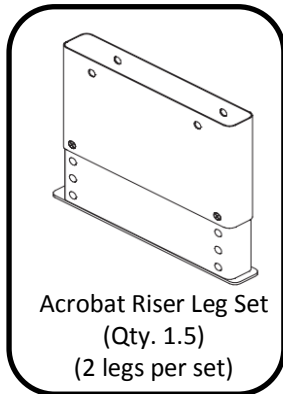
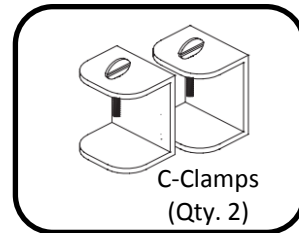
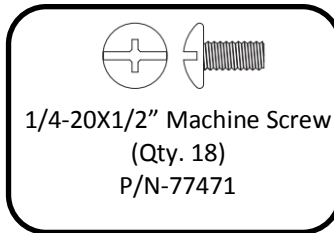
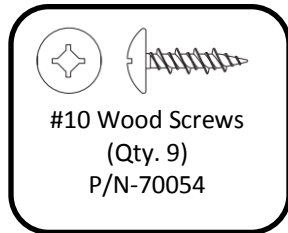

Special Notes

1. Check that all of the components are accounted for and undamaged before assembling.
2. Please assemble the product in clean and dry area.
3. For larger units you may need another person to help assemble the product.
4. Clean the product with a mild cleaner and a damp cloth.

Tools

You will need a Phillips head screwdriver.

Notes

If you have damaged or missing components or hardware, please contact customer service at 1 (800) 328-1061



Corner Riser Shelf Assembly Instructions

Step 1: Place the table top on a smooth clean surface, laminate face down. Proceed to align the brackets with the predrilled holes, then attach the brackets to the top using the (9) #10 screw and a Phillips head screwdriver (See Drawing 1A). Using the supplied screws, attach the leg to the brackets using (12) 1/4-20x1/2" Machine Screws, (4) per leg (See Drawing 1B)

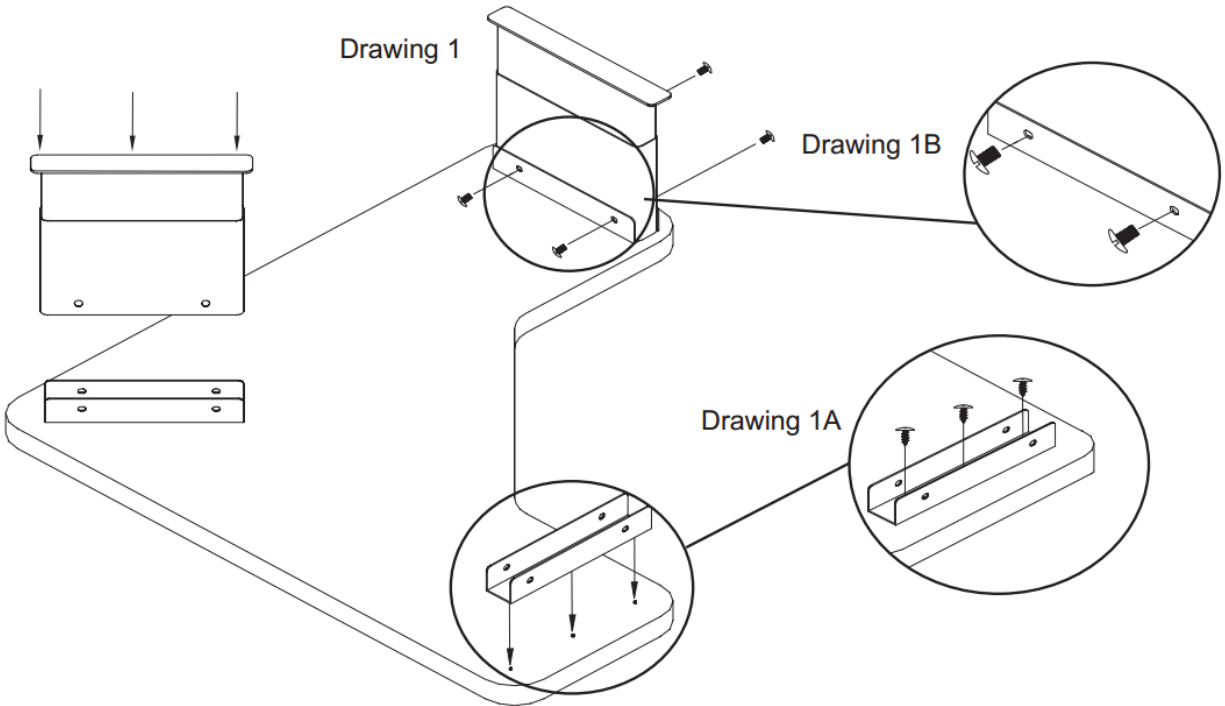

Step 2: Turn over the riser shelf and place it on the laminate surface. Next, place the (2) c-clamps on the two outside legs, which go over the thin piece of metal that is connected to the leg (See Drawing 2A). Tighten down the c-clamp so the riser shelf is secure using the thumb screws.

