

PRODUCT SPECIFICATION:

UXL ADJUSTABLE CHAIR: MODEL:

PART NUMBERS:

XL031P_P_ (W/ GLIDES)
 XL035P_P_ (W/ CASTERS)
 XL031P_P_LR (W/ GLIDES & ARMS)
 XL035P_P_LR (W/ CASTERS &
 ARMS)
 XL031F_P_ (W/ GLIDES + FABRIC
 SEAT)
 XL035F_P_ (W/ CASTERS + FABRIC
 SEAT)
 XL031F_P_LR (W/ GLIDES, FABRIC
 & ARMS)
 XL035F_P_LR (W CASTERS,
 FABRIC & ARMS)

SEAT COLOR CHOICE FOR 1ST _
 SEAT BACK COLOR CHOICE FOR 2ND _

Chair frame – 0.59"x1.18"x0.078" thick oval shaped steel tube and 3mm thick steel plate x 2mm thick round steel tube fully welded and with a powdercoat paint finish.

Backrest and Seat – made of 100% virgin polypropylene material with high impact strength The Backrest is supported with a metal bar insert that provides very strong support.

Swivel/Vertical Pneumatic height adjustment mechanism – no tilting.

Durable Nylon casters 50mm diameter.

DIMENSIONS:

Overall size:

D32.62"xW19.29"xH30.51"-34.84"

Seat Height: 16.34" – 20.67"

Seat Depth: 22.25"

Seat Width: 19.29"

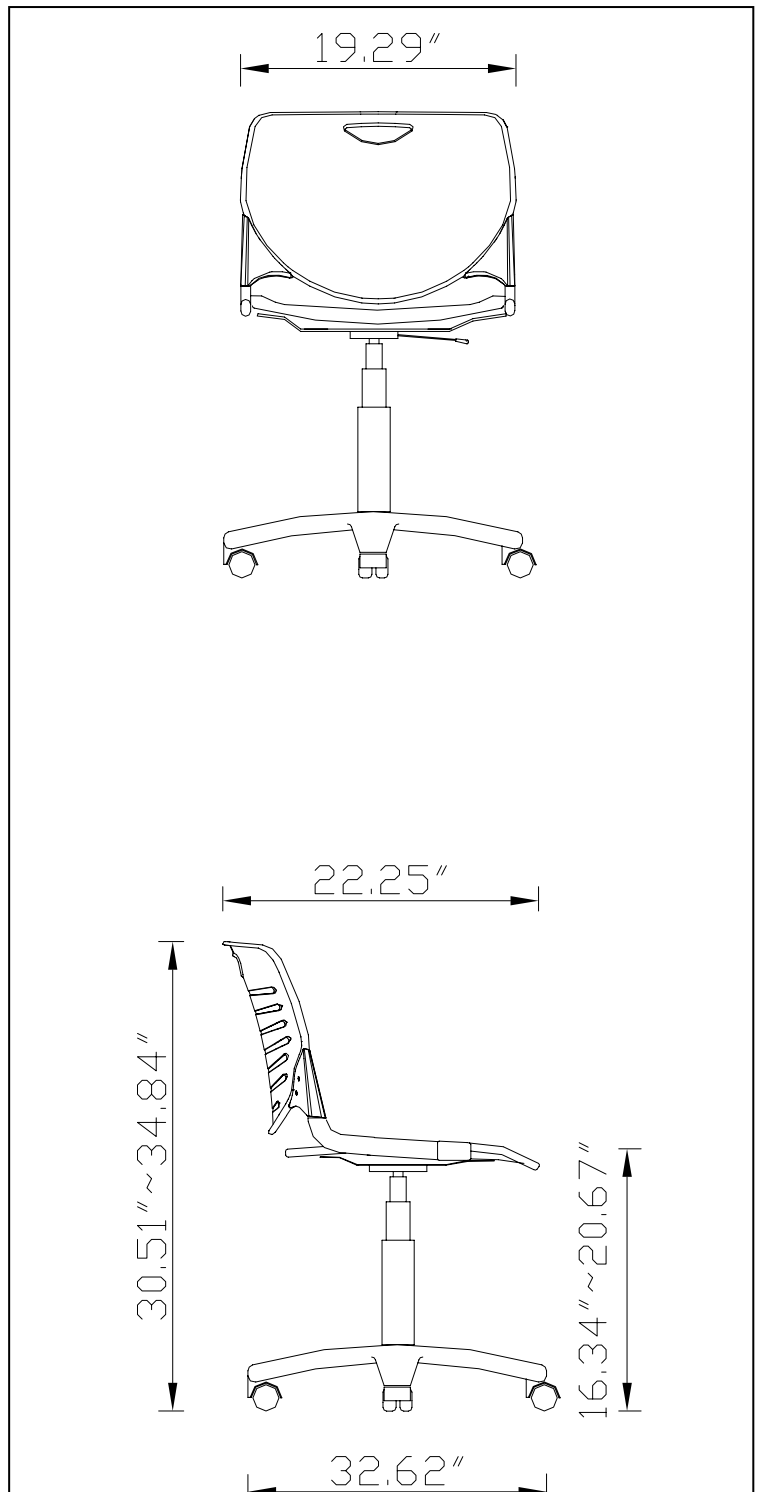

FREIGHT:

Carton Dimensions

(For Smith System input)

AVAILABLE COLORS:

Frame Colors: Shell (SEAT & SEATBACK) Colors:

PLATINUM	Apple (A), Black (B), Blueberry (C), Burgundy (D), Cerulean (S), Chocolate (Q), Clementine (E), Forest Green (F), Fuchsia (G), Mint (H), Mocha (T), Navy (I), Persian Blue (J), Purple (K), Red (L), White (M), Yellow (N).
----------	---

