

# MODEL #26512, 26515, 26516, 26522

## Acrobat Bullet Workstations

### DESIGN:

The strong, stable Acrobat Workstations can be used separately or in multiple combinations. It features a built-in wire raceway in the modesty panel for cable management.

### MATERIALS:

The 1 1/4" thick work surface consists of a 45 lb. density particle board core with a .030" high-pressure laminated surface and a .020" melamine backer sheet. The edge of the work surface features 3/8" bumper edge molding that is mechanically fastened every 6 to 8 inches to assure a long lasting fit. The top is pre-drilled for ease of installation.

The Legs are telescoping which allows height adjustment from 24 1/2" to 36 1/2" high. The legs are 1 5/8"W x 10"D double wall panel constructed of 12, 14 and 18-gauge steel with rounded edges. Cable ports in the upper leg create networking options from station to station and in the lower leg cable ports provide routing to the floor. The base is 16-gauge steel tube 1 3/4" x 2" nylon caps protect the feet. The legs also have 1" adjusting leveling glides.

The modesty panel is made from 18-gauge steel and features a built in raceway and cable ports in the upper corners. The panel connects to the worksurface and legs. Acrobat workstations can go mobile with optional 3" or 4" dual wheel casters.

### PRODUCT SPECIFICATIONS:

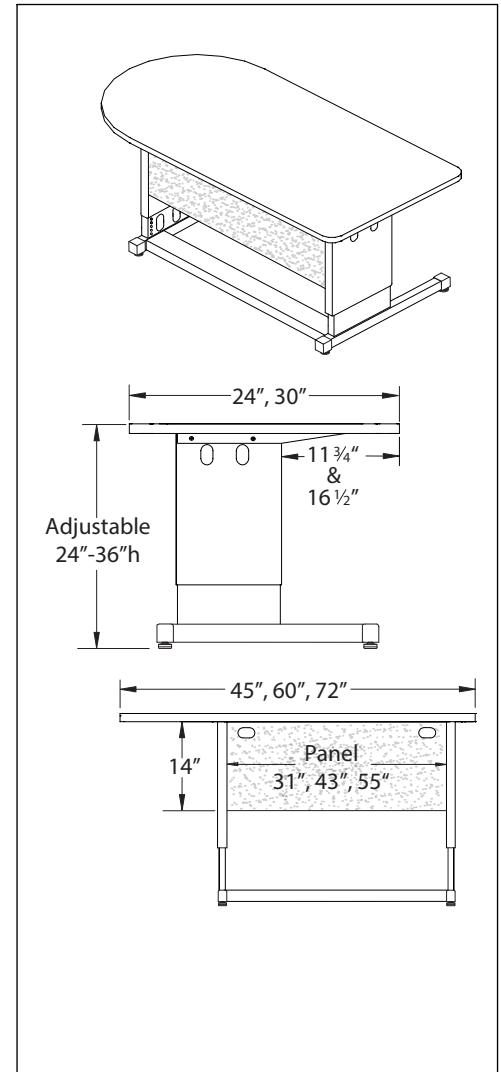

### DIMENSIONS & FREIGHT: Product is NOT UPSable

Model	Description	D"	W"	H"	F.C.	Cube	Wt.
26512	Acrobat Bullet Workstation	30	45	24-36	70	5.0	99 lbs.
	26512 Carton Dimensions	31 1/8	51 1/4	3 1/8			
26515	Acrobat Bullet Workstation	24	45	24-36	70	4.8	92 lbs.
	26515 Carton Dimensions	25 1/8	51 1/4	3			
26516	Acrobat Bullet Workstation	30	60	24-36	70	6.3	115 lbs.
	26516 Carton Dimensions	31 1/8	63	3 1/8			
26522	Acrobat Bullet Workstation	30	72	24-36	70	7.3	129 lbs.
	26522 Carton Dimensions	31 1/8	75 1/4	3 1/8			

### AVAILABLE COLORS:

Acrobat Desk  
Leg Color Choice

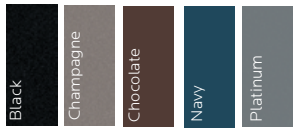

Acrobat Laminate Color Choice



Acrobat Edge Color Choice



**1 1/4" Tops**

Acrobat Workstations Have Top and Edge Choices

**CHOICE 1** - 1 1/4" top with Bumper T-Mold  
no letter to follow Model No.

**CHOICE 3** - 1 1/4" top with 4mm T-Mold  
**D** to follow Model No.