



# Product Specifications

## Graphic Arts Table

**Model# 27346 & 27348**

Planner Graphic Arts Tables bring their sturdy construction features to the art classroom. The split-top model adds a flat work area for maximum workspace.

Qty: \_\_\_\_\_

Color: \_\_\_\_\_

## Material

The **work surface** consists of a 7/8" thick high-pressure laminate bonded to a 45-lb. density particle board core with a backer sheet and 3mm flat edges around the perimeter. The unit is constructed with a continuous hinge along the (width) front of the work surface, allowing up to 45 degrees of articulation of the work surface. The unit arrives with a curved easel attached to adjust the work station to the desired position.

The **front & back channels** come pre-assembled and are fully welded and constructed of 2" x 3" 14-gauge steel and provides lateral stability and a no sag work surface. The back channel has a 14-gauge plate welded inside the brace to support the 16-gauge curved easel. The **legs** are height adjustable for unit adjustment of 29" to 39" easily accommodating seating. Upper leg section is constructed of 1 1/4" square 14-gauge steel tubing. Lower leg inserts have tapped holes on 1" centers and attach to upper legs with 2 socket screws per leg. Legs are secured to the 3" x 1" 14-gauge leg brace by MIG weld. Each leg has a 1" adjusting leveling glide for stability.

## Dimensions

27346 - 24"d x 36"w x 29-39"h

27348 - 30"d x 42"w x 29-39"h

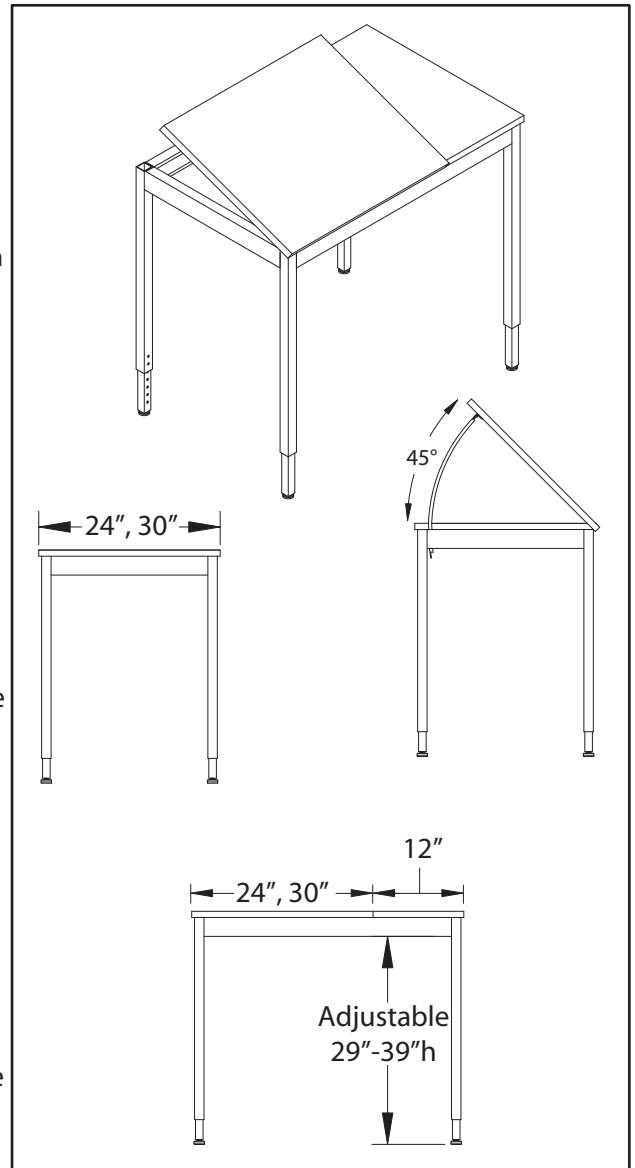

For more information call 1-800-328-1061 or email: [furniture@smithsystem.com](mailto:furniture@smithsystem.com)

## Available Colors

Maple/Maple Edge/Champagne Frame

Gray/Black Edge/Black Frame

## Freight

Weight: 27346- 62 lbs.

27348- 80 lbs.

Freight Class: 70

USPable

Ships in Two Boxes

