

ASSEMBLY INSTRUCTIONS

INTERCHANGE™

KIDNEY, HALF-MOON & TRAPEZOID ACTIVITY TABLES

INTERCHANGE HALF-MOON ACTIVITY TABLE

04128 Interchange Activity Table - Half-Moon

INTERCHANGE TRAPEZOID ACTIVITY TABLE

04127 Interchange Activity Table - Trapezoid

INTERCHANGE KIDNEY ACTIVITY TABLE

04130 Interchange Activity Table - Trapezoid



*For assistance in assembling product, missing or damaged parts,
or to place an order, please contact Customer Service at 800-328-1061.*



HARDWARE AND COMPONENTS

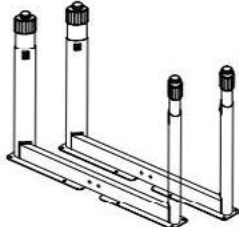

Leg Set
P/N: See Table
(QTY: 1 Leg Set)



Support Channel/Brace
P/N: See Table
(QTY: 1)

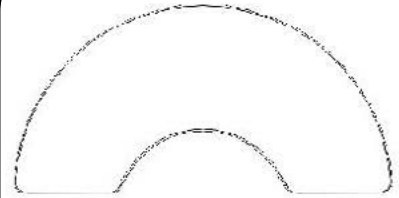
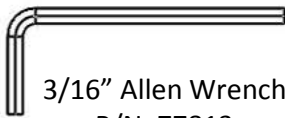
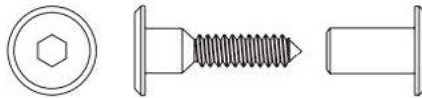

Table Top
(QTY: 1)



3/16" Allen Wrench
P/N: 77813
(QTY: 2)



P/N: 70867 – Connector Bolt 1/4-20 x 23mm
P/N: 70869 – Connector Nut 1/4-20 x 17mm
(QTY: 4 of each)

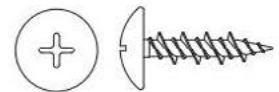

#10x3/4" Wood Screw
P/N: 70054
(QTY: 26)



Interchange Angle Bracket W/ Hardware
P/N: 77513
(QTY: 1 Pair)

INTERCHANGE™ ACTIVITY TABLE REPLACEMENT HARDWARE PACKS

[1] 67607 HARDWARE PACK, INTERCHANGE ACT 42" 48"

QTY 2	#77813 - 3/16" ALLEN WRENCH
QTY 4	#70867 - CONNECTOR BOLT 1/4-20 X 23MM
QTY 4	#70869 - CONNECTOR NUT 1/4-20 X 17MM
QTY 26	#70054 - #10 X 3/4" WOOD SCREW

[2] 67205 REPL. HARDWARE SILHOUETTE LEGS

QTY 2	#77813 - 3/16" ALLEN WRENCH
QTY 12	#70054 - #10 X 3/4" WOOD SCREW
QTY 4	#70086 - SCREW, CAP HEAD M8X10MM
QTY 4	#77741 - 3/8 - 16 X .625 HALF DOG SOCKET SCREW

ASSEMBLY INSTRUCTIONS

STEP 1: Place the top on a clean, dry surface, laminate side down, so that the predrill holes face up.

STEP 2: Loosely attach the support brace to the angle brackets using (4) connector bolts that were provided with the angle brackets (#77513). Then connect the Leg sets to the Angle Brackets using the (4) connector bolts and (4) connector nuts. (see drawing 1).

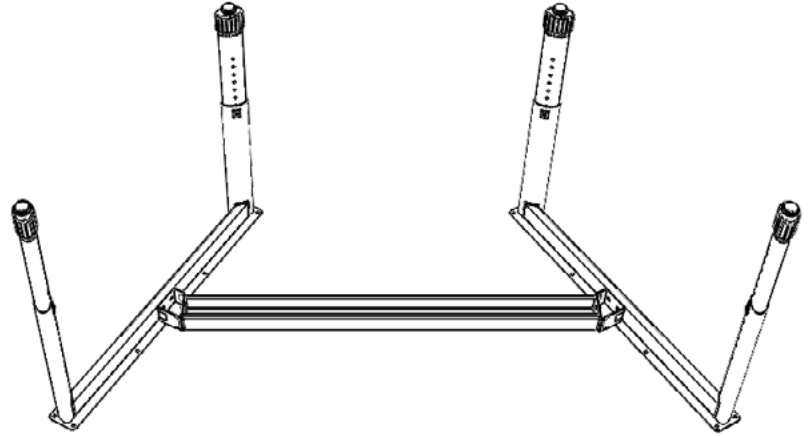

STEP 3: Align the slots of the Leg Assembly to the pre-drilled holes of the top. Using the 3/4" wood screws provided, attach the leg assembly to the top.

ASSEMBLY TIP: *Stagger the installation of the screws. (i.e. fasten one screw on one leg assembly - then move to the other leg assembly and fasten one screw - and then back to the other leg assembly and so forth)*

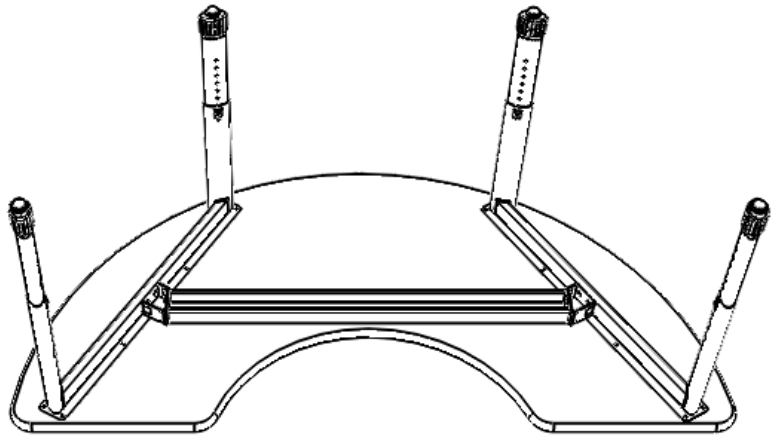

STEP 4: Tighten the connector bolts and nuts to the channel, attached in Step 2, using both hex keys provided.

ASSEMBLY INSTRUCTIONS

STEP 5: Adjust the leg height as needed by loosening the set screw in the leg (use the hex key to loosen). Tighten the set screws. Hand tighten, using hex key provided - DO NOT use a power tool to - ensure the set screw is inserted correctly into the height-adjustment hole.

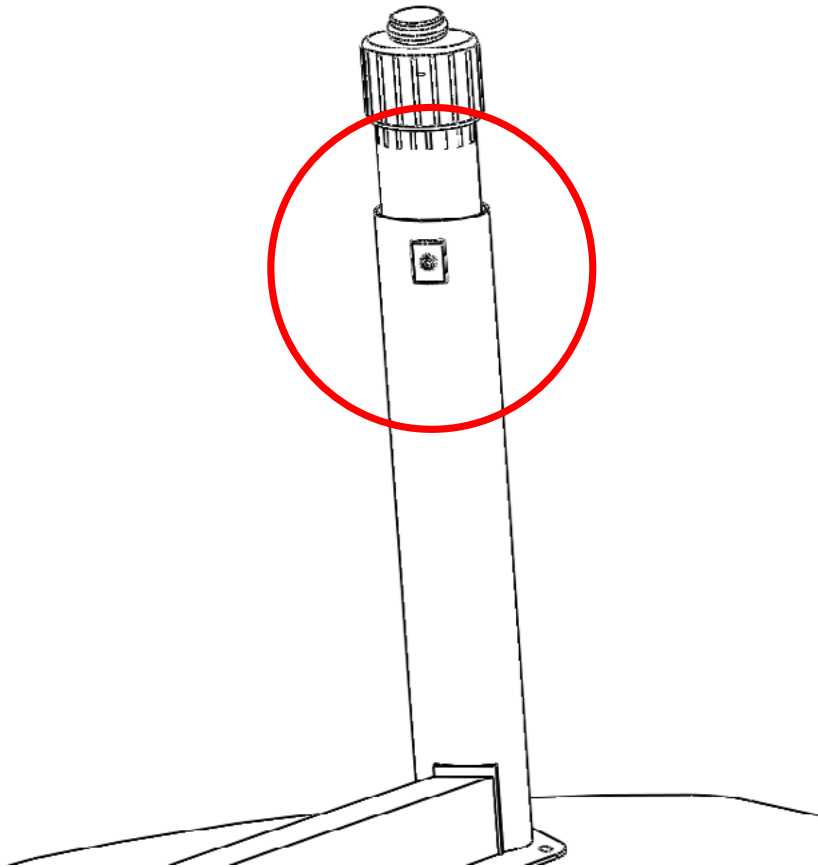

STEP 6: Use the help of at least one other person and turn the table over to the upright position.