

TEACHER DESK - DOUBLE DRAWER PED MODEL 24010



If you have damaged or missing components please contact customer service.

800-328-1061

www.smithsystem.com



PARTS LIST

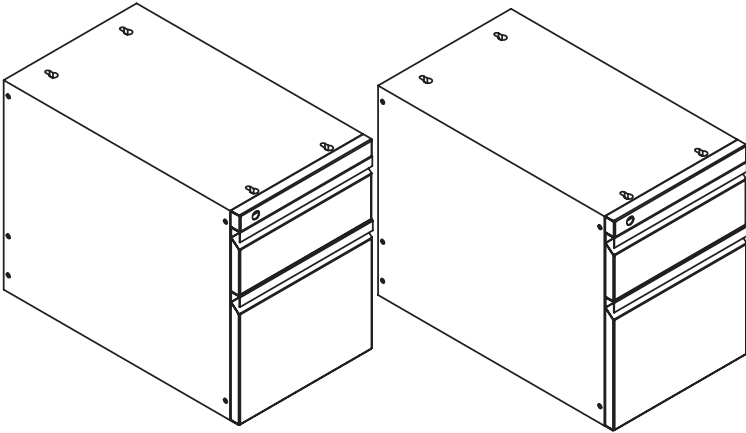

DESCRIPTION: DRAWER PED
QTY PER UNIT: 2
PART NUMBER: 19180
COLORS: BLA; CMP; PLT

DESCRIPTION: 30" X 60" TOP
QTY PER UNIT: 1
PART NUMBER: 68657
COLORS: CHOICE OF LAMINATE;
CHOICE OF T-MOLD

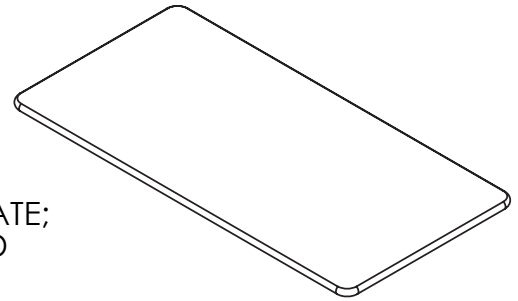

DESCRIPTION: DOUBLE PED LEG SET (INCLUDES HDWR AND MODESTY PANEL)
QTY PER UNIT: 1
PART NUMBER: 19182
COLORS: BLA; CMP; PLT

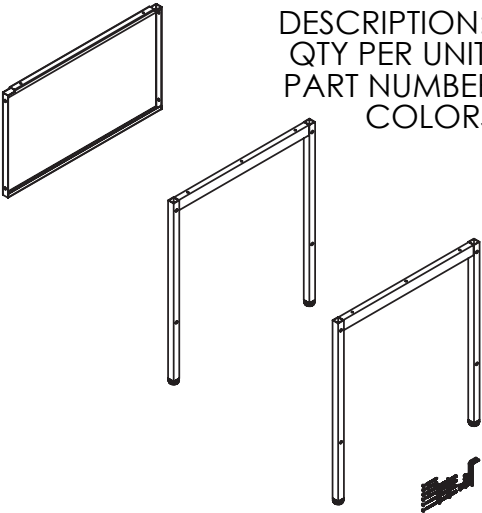

If you have damaged or missing components please contact customer service.

800-328-1061
www.smithsystem.com

1. LAY THE TOP UPSIDE DOWN, WITH THE CUT OF THE T-MOLD AT THE BACK AND MAKE SURE THE LAMINATE IS FACE DOWN AND THE PRE-ATTACHED MOUNTING PLATES ARE FACING UPWARDS.

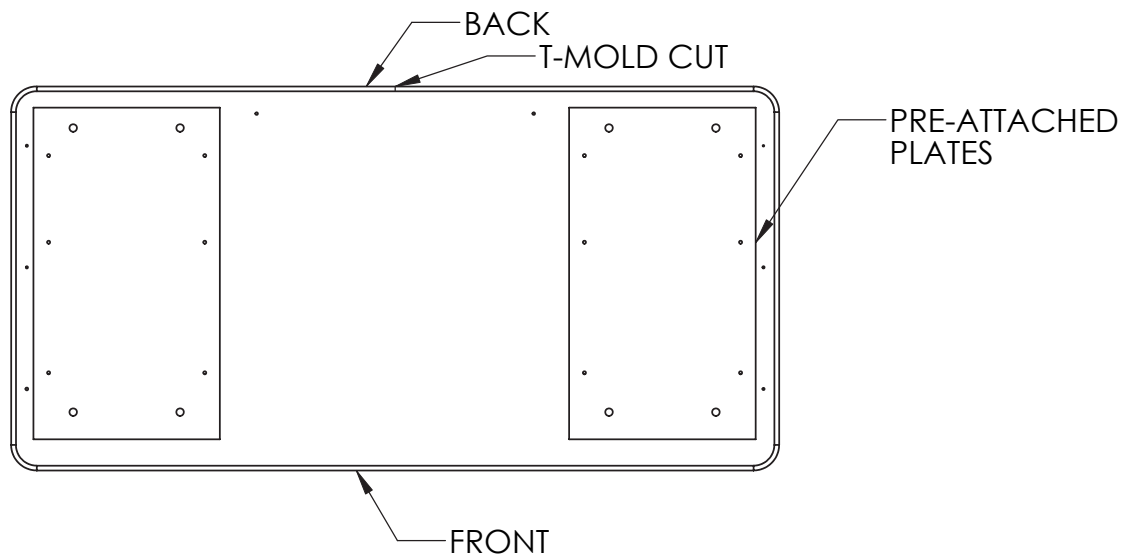

2. REMOVE BOTH DRAWER PEDS FROM THEIR CARTONS. TURN THEM UPSIDE DOWN SO THE KEYHOLE-SHAPED SLOTS ARE FACE DOWN.

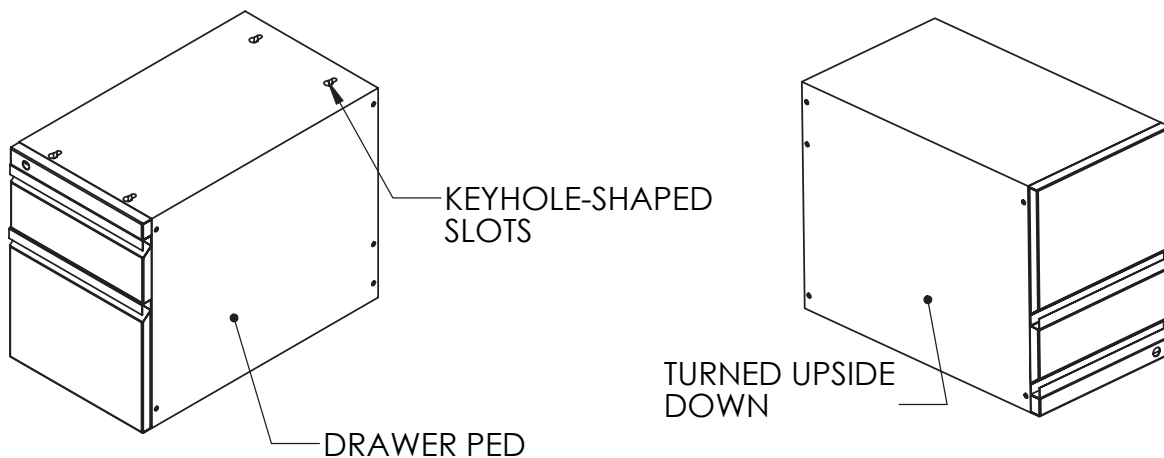

3. SECURE DRAWER PED ON MOUNTING PLATE. ALIGN SLOTS ON DRAWER PED TO KNOBS ON MOUNTING PLATE. BE CAREFUL NOT TO FORCE THE PARTS TOGETHER. THE KNOBS ON THE PLATE SHOULD COMFORTABLY ALIGN WITH THE SLOTS. ONCE THE PED IS SEATED ON THE PLATE, SLIDE THE PED FORWARD (TOWARDS YOU).

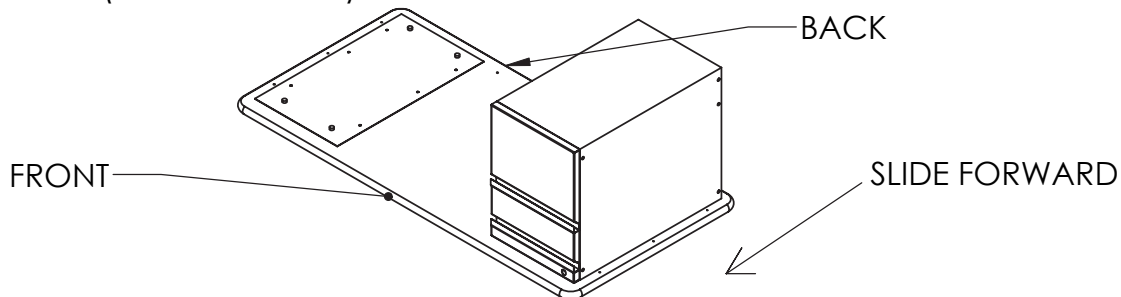

4. REPEAT STEPS 2 AND 3 WITH THE REMAINING DRAWER PED.

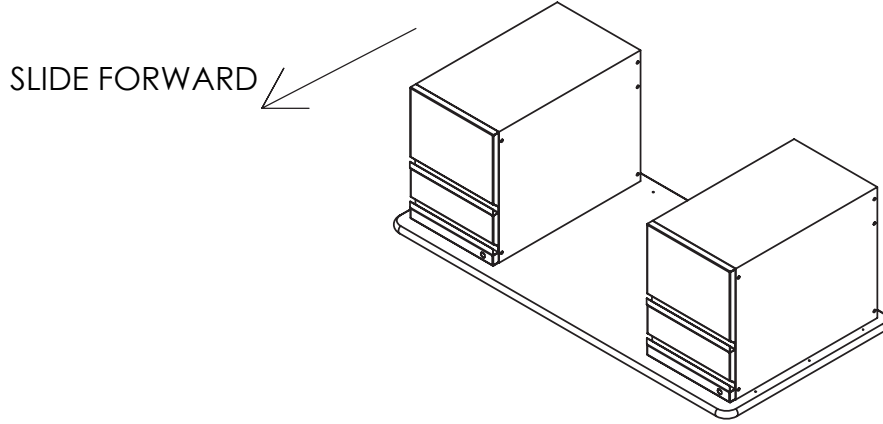

5. ATTACH LEGS TO DRAWER PEDS USING CONNECTOR BOLTS

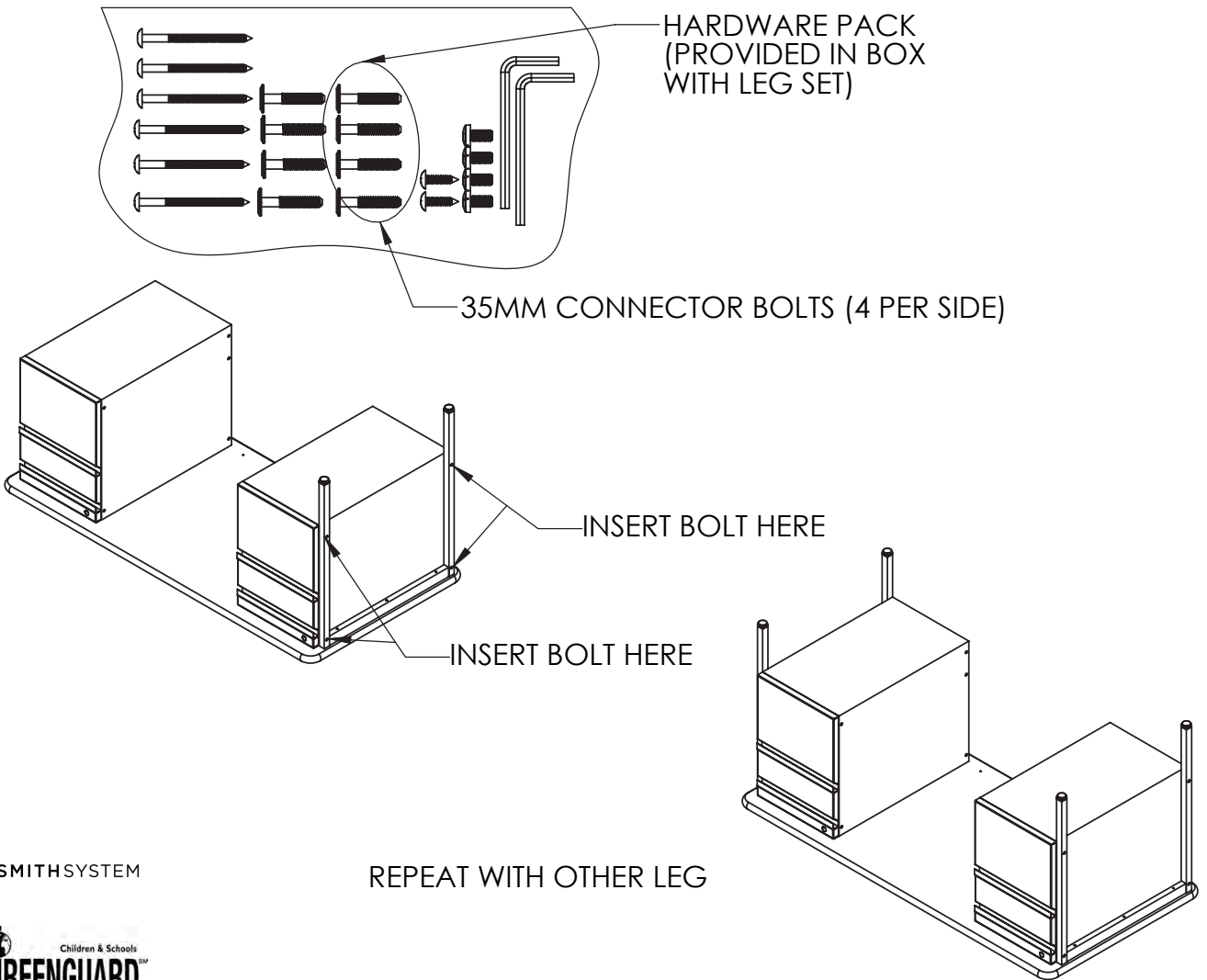

6. ATTACH PANEL TO DRAWER PEDS.

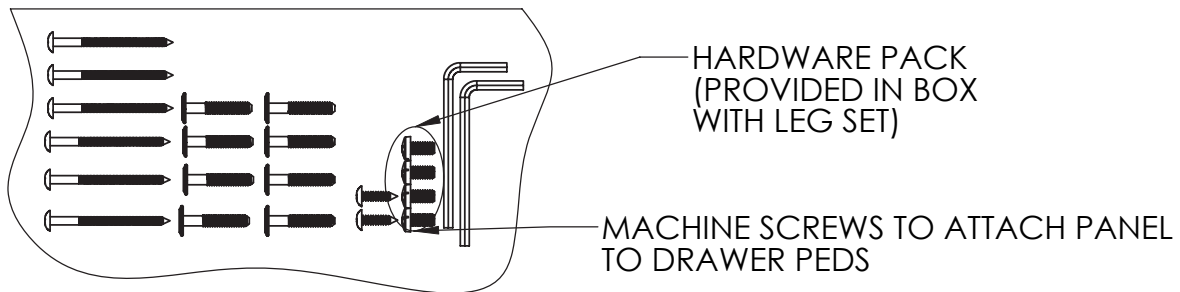
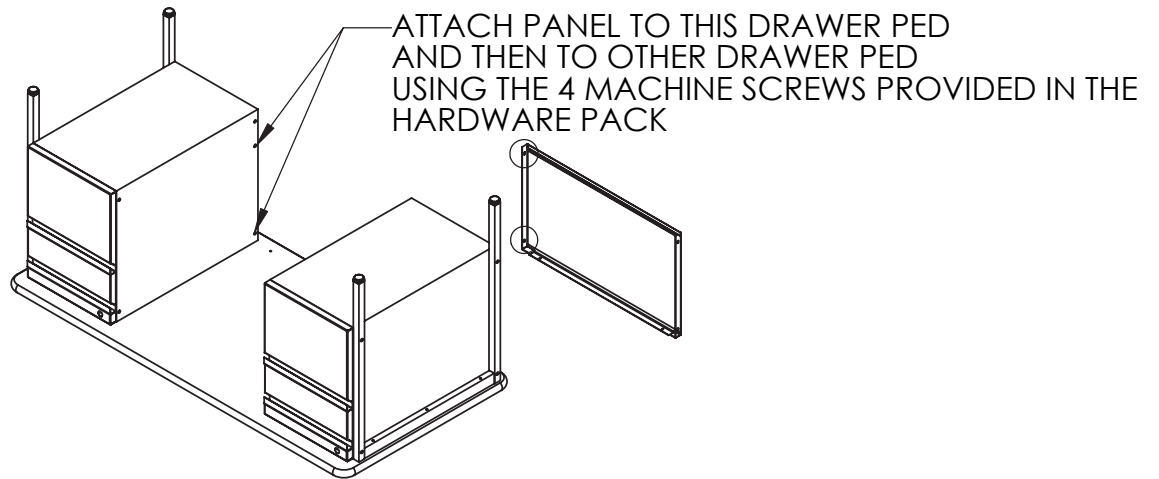

7. ATTACH PANEL TO TOP.

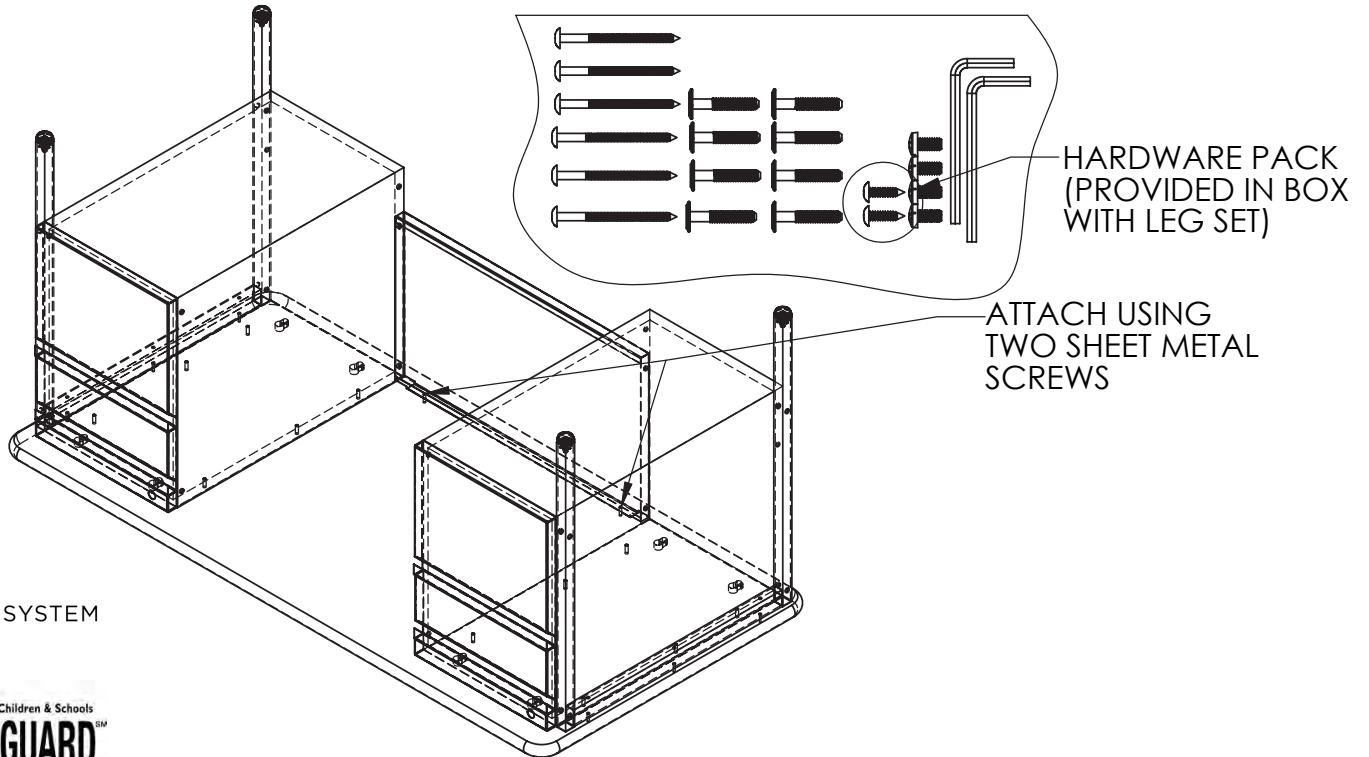

8. ATTACH THE LEGS TO THE TOP.

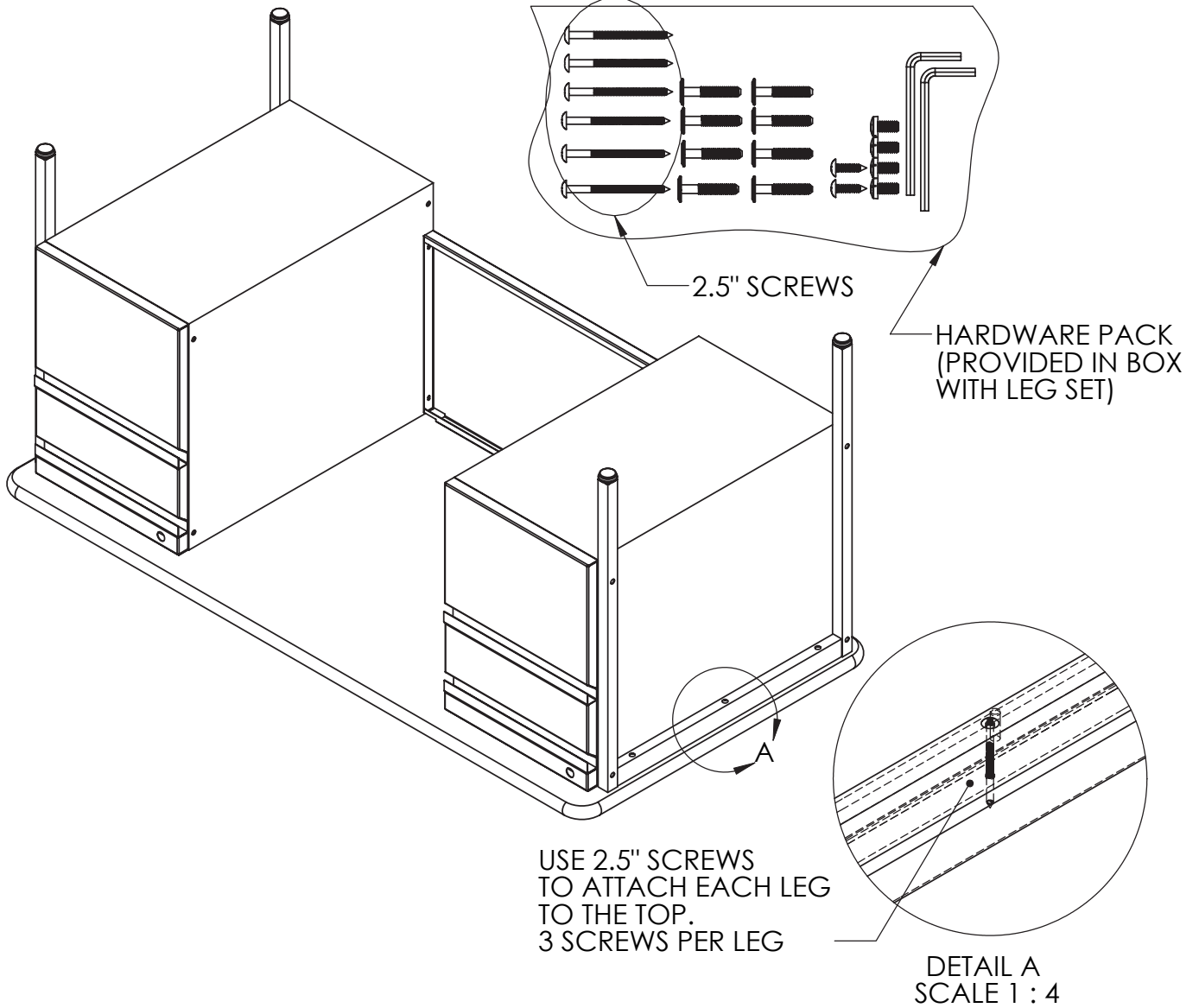

9. THE UNIT IS NOW ASSEMBLED. YOU SHOULD NOT HAVE ANY REMAINING SCREWS IN THE HARDWARE PACK. TIGHTEN THE MACHINE SCREWS AND THE SHEET METAL SCREWS USING AN ELECTRIC DRILL AT THE LOWEST TORQUE SETTING. HEX KEYS ARE PROVIDED TO ASSIST TIGHTENING THE CONNECTOR BOLTS.

10. USING THE HELP OF AT LEAST ONE OTHER PERSON, TURN THE UNIT OVER (UPRIGHT).

NOTE: USE CAUTION WHEN REPOSITIONING THE UNIT AT ANY TIME. DRAGGING THE DESK ACROSS THE FLOOR OR ROCKING THE DESK ON 2 OF THE 4 LEGS WILL WEAKEN THE INTEGRITY OF THE ASSEMBLY.