

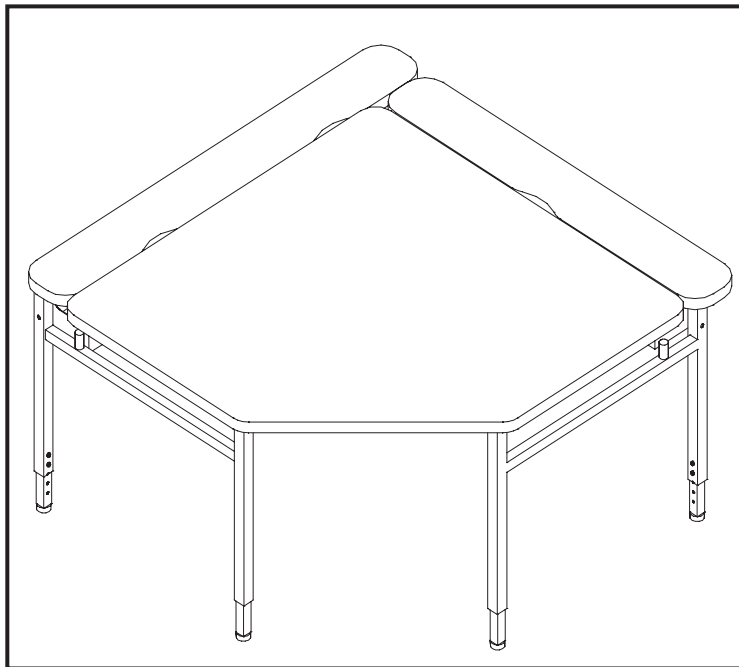

Access Corner Station

Assembly Instructions



For assistance in assembling product, missing or damaged parts, or to place an order please contact customer service at 1-800-328-1061. You may also place your order online at

www.smithsystem.com

Special Notes

1. Check that all components are accounted for and undamaged before assembling.
2. Please assemble product in a clean and dry area.
3. For larger units you may need another person to help assemble the product.
4. Clean the product with a mild cleaner and a damp cloth.

Tools

You will need a Phillips head screw driver.

Notes:

If you have damaged or missing components or hardware please contact customer service at 1 (800) 328-1061.

Hardware and Components

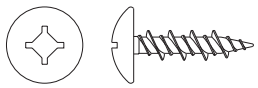

#10 Wood Screws

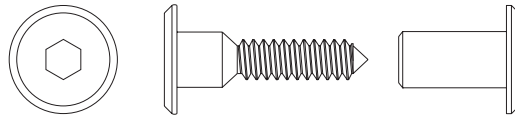

1/4"-20UNC Connector Bolt (4)

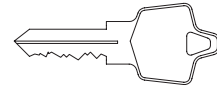

Key



Wrench (2)



3/8"-16 Dog Nut Screw
(located in each PSD-Leg, 2-per leg)

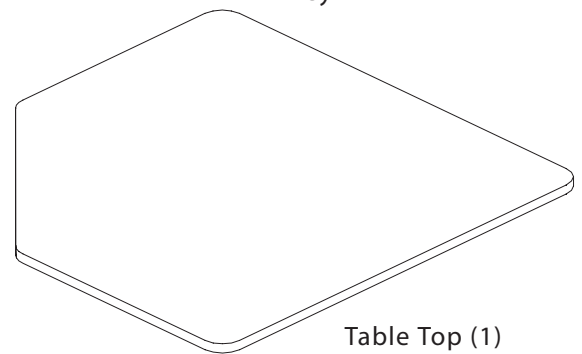
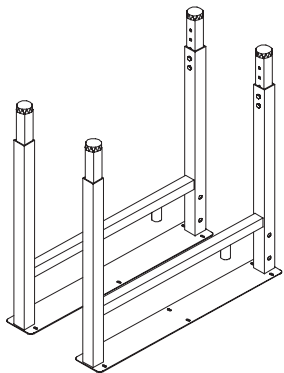
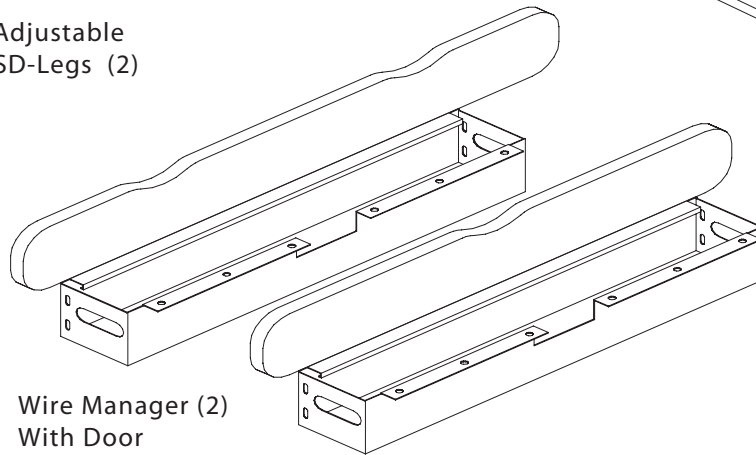

Table Top (1)



Adjustable
PSD-Legs (2)



Wire Manager (2)
With Door

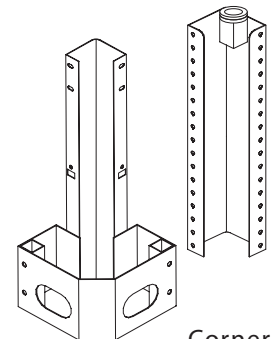

Corner Leg (1)

URGENT:

Please make sure you have received all hardware and components before assembling product.

If you have damaged or
missing components please
contact customer service.

1-800-328-1061

Access Station Directions

Step 1 First attach the corner leg, using (2) Connector Bolts (located in your hardware pack), to the wire manager. (See Drawing 1A). Next attach the PSD leg on the opposite side using (2) Connector Bolts. (See Drawing 1B). Keep bolts finger tight until the table is completely assembled.

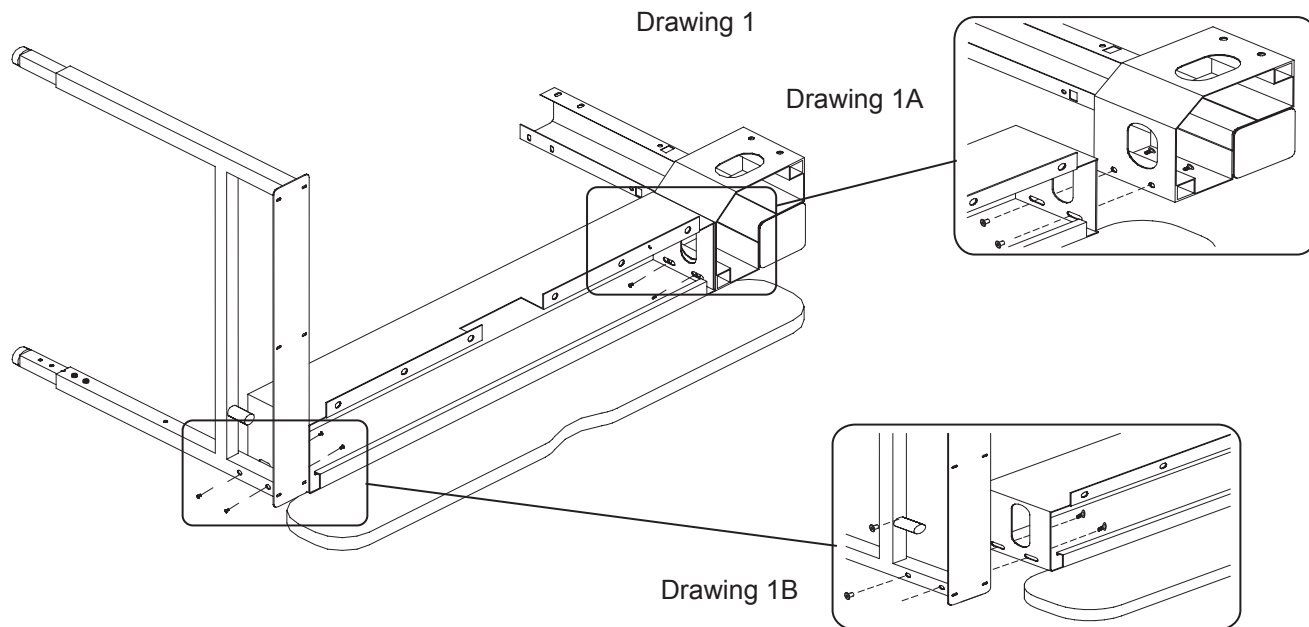

Step 2 Now place the wire manager which is connected to both legs on a smooth, clean surface with the bottom facing up. Next adjust the PSD leg to desired height. (See Drawing 2A). After that, adjust the corner leg to the desired height. (See Drawing 2).

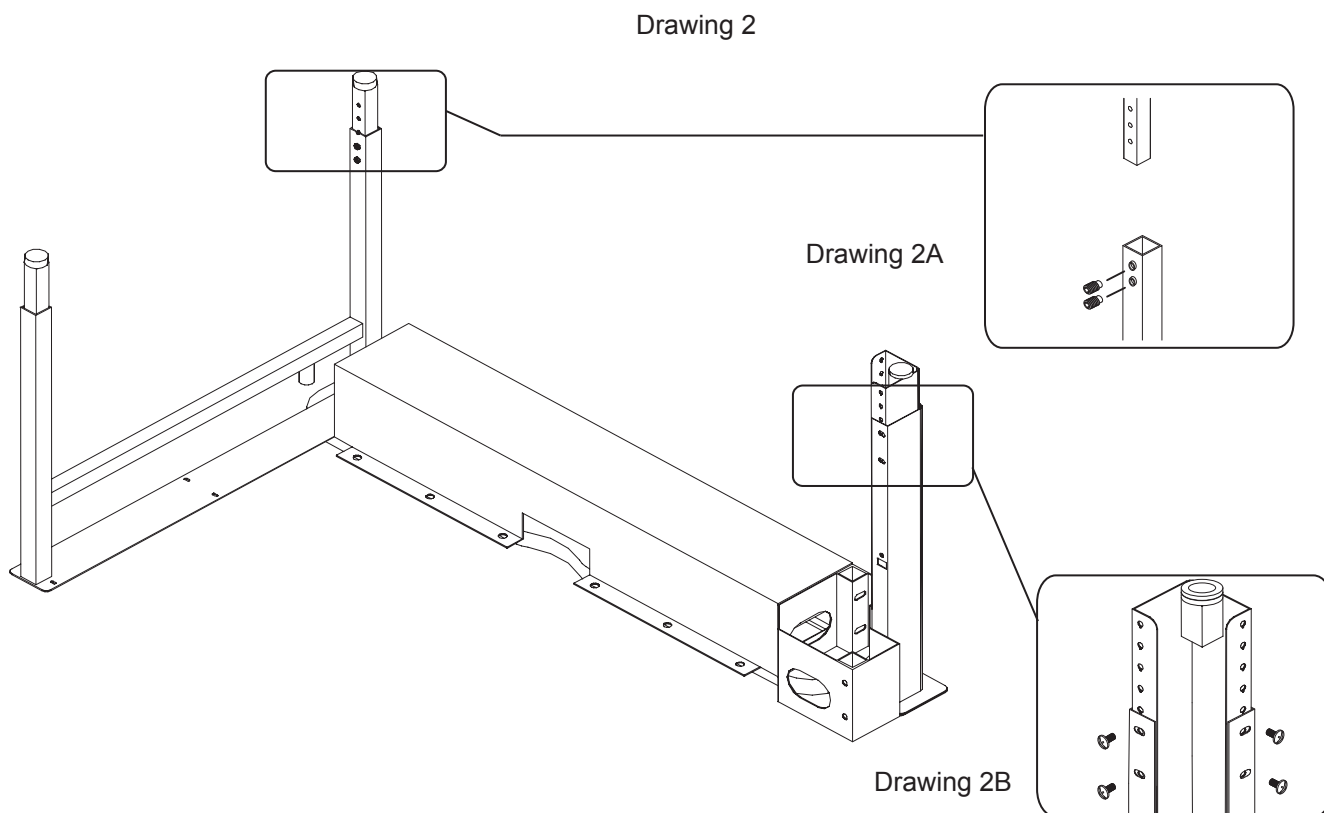

If you have damaged or missing components please contact customer service.

1-800-328-1061

Assembly Instructions (cont.)

Step 3 Attach the other PSD leg using (2) Connector Bolts to the wire manager. (See drawing 3B). Then adjust the PSD leg to desired height. (See Drawing 3A).

Drawing 3

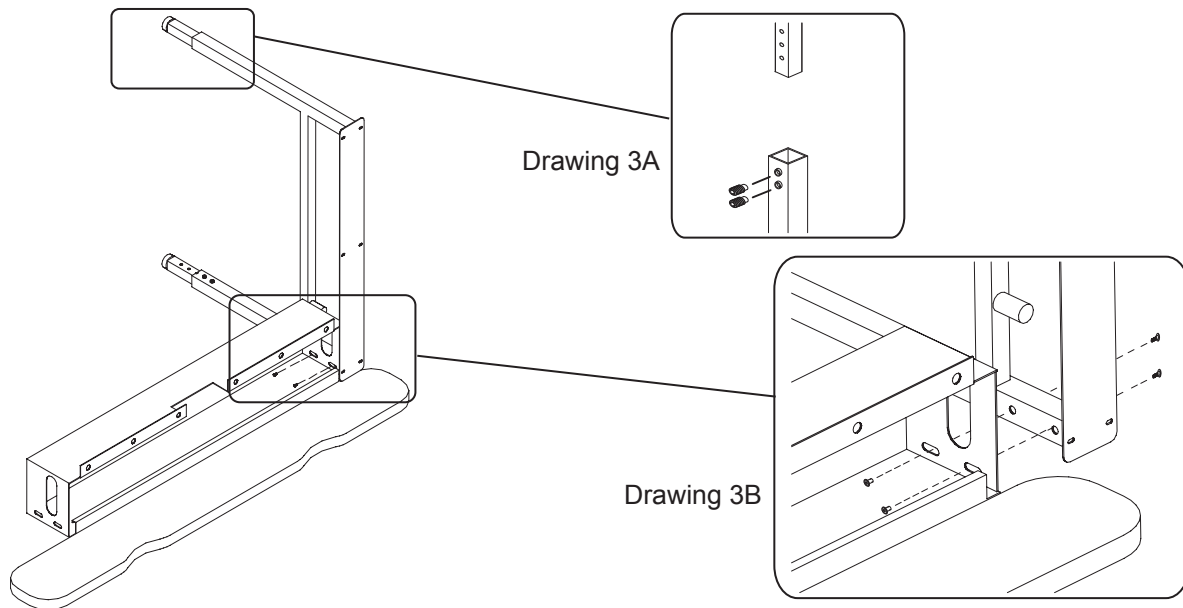

Step 4 Flip over the assembled frame over which was made in step 2. (Reference to drawing 4 for help). Then flip over the other wire manager which was assembled in step 3 and align the holes from the wire manager to the corner leg. Next screw the wire manager to the corner leg using (2) Connector Bolts. (See Drawing 4A).

Drawing 4

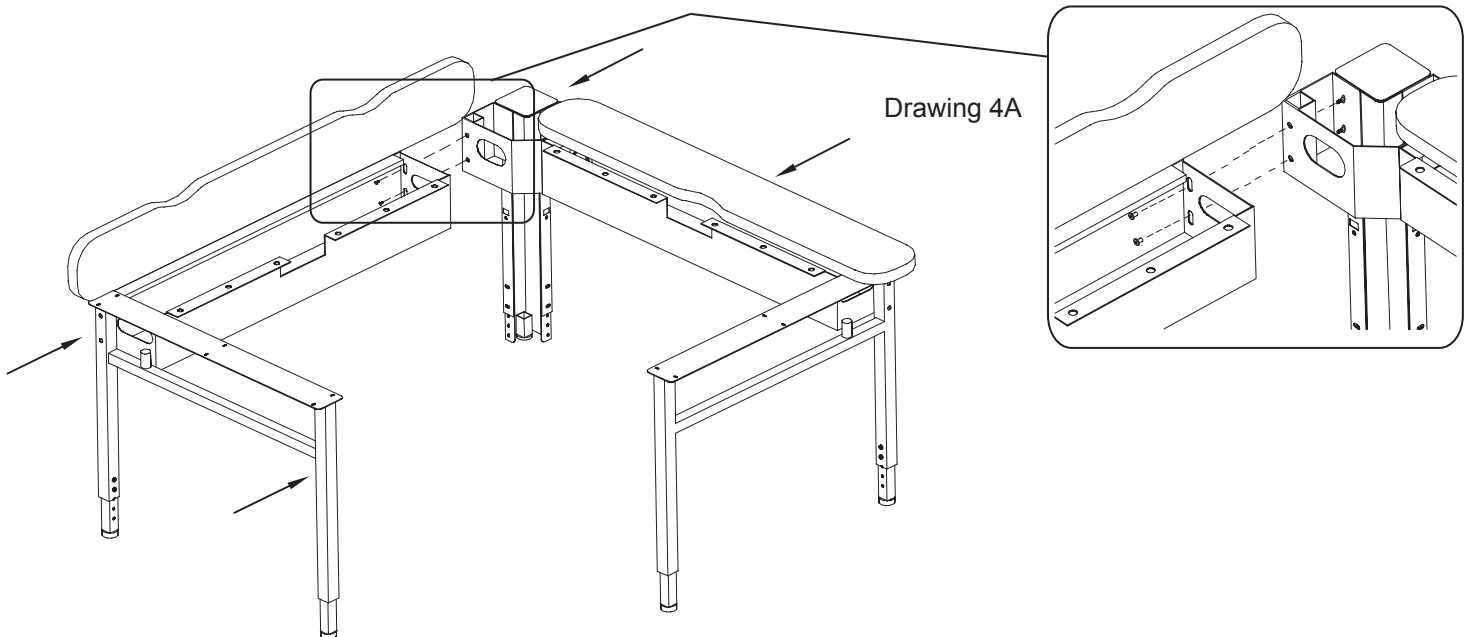

If you have damaged or missing components please contact customer service.

800-328-1061

www.smithsystem.com

Assembly Instructions (cont.)

Step 5 Next gently slide the table top with the top facing up on the assembly frame from step four. Then align the predrilled holes underneath the table top with the wire manager and the PSD leg. Verify alignment before you start screwing in the top. Next attach the PSD legs using (4) Truss Head Screws to the table top through the predrilled holes. Do not place screws in the back two holes of leg. (See Drawing 5B). Then screw the wire manager into the table top using Truss Head Screws. (See Drawing 5A).

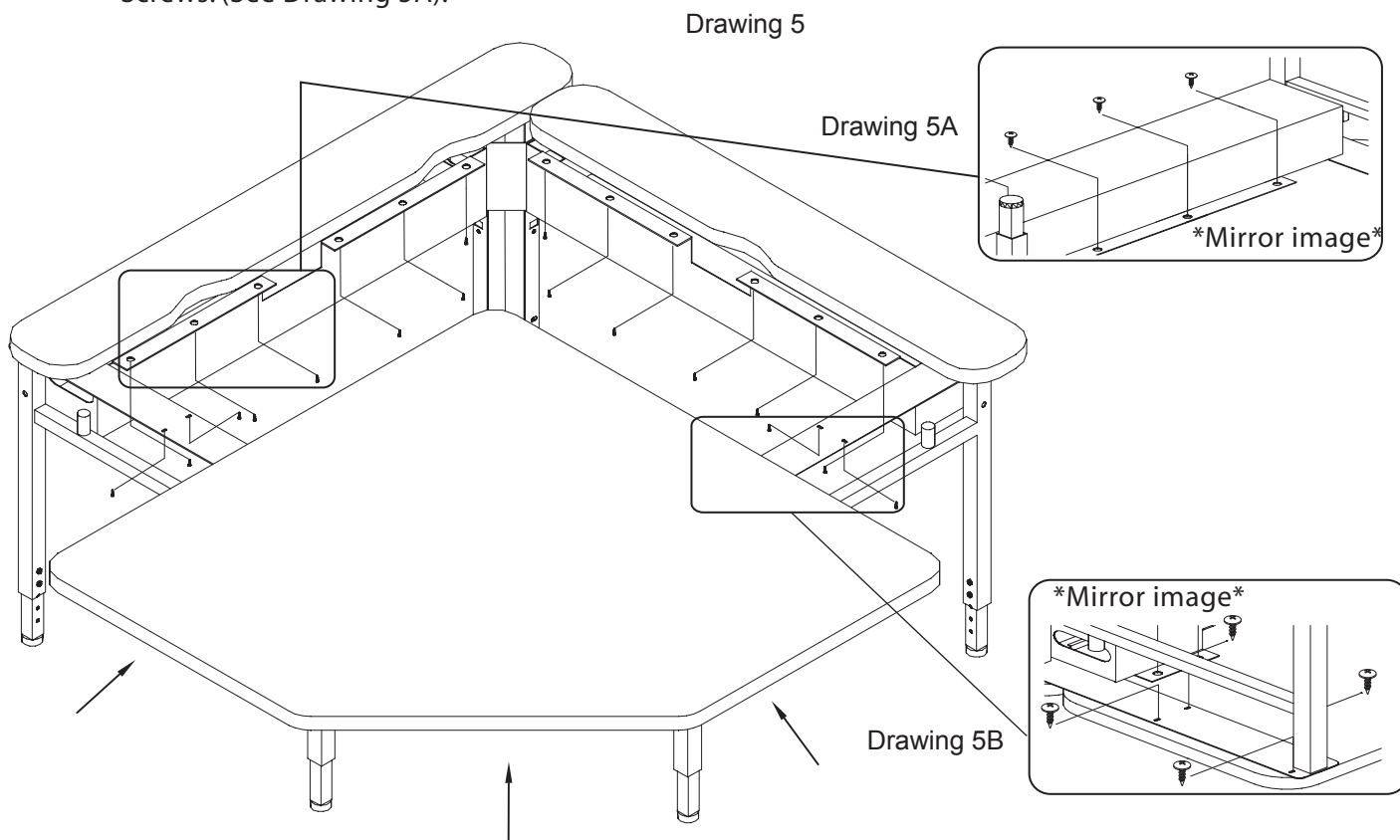

Step 6 Now go back and tighten all the screws referenced in all 5 steps. Your desk is ready for use.

