

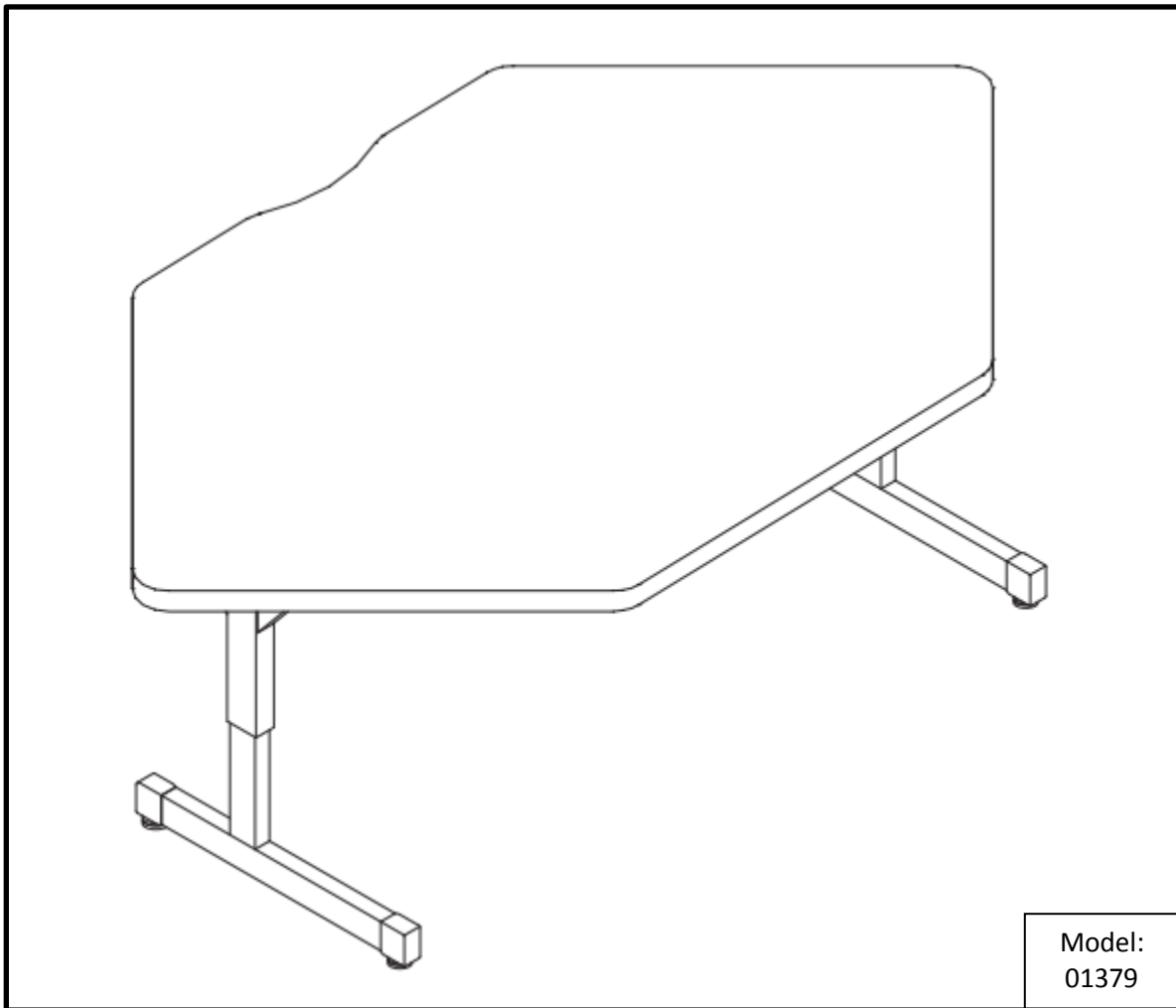

SMITH SYSTEM

Furniture for inspired learning.

Flexline Corner Workstation Assembly Instructions



SMITH SYSTEM



For Assistance in assembling product, missing or damaged parts,
or to place an order, please contact customer service at 800-328-1061
You may also place your order online at
www.smithsystem.com

Hardware and Components

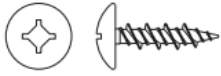

#10x3/4" Wood Screw
P/N: 70054
(QTY: 32)

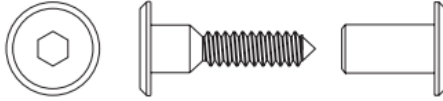

P/N: 70867 – Connector Bolt 1/4-20x23mm
P/N 70871 – Connector Nut 1/4-20x17mm
(QTY: 8 of each)



Button Hd Scrw M8x20mm
P/N: 70088
(QTY: 3)



Allen Wrench 3/16"
P/N: 77813
(QTY: 4)



3/8"-16x.625 Dog Nut Screw
P/N: 77741
(QTY: 8)

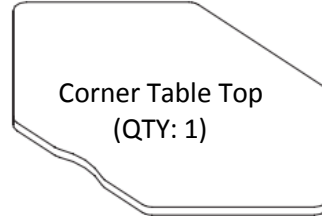

Corner Table Top
(QTY: 1)

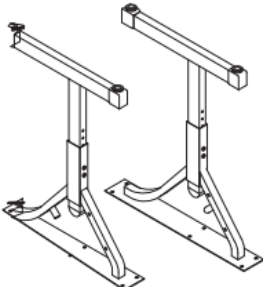

Y- Leg Sets
(QTY: 1 set of 2 Legs)

Modesty Panel
P/N: 17520
(QTY: 2)

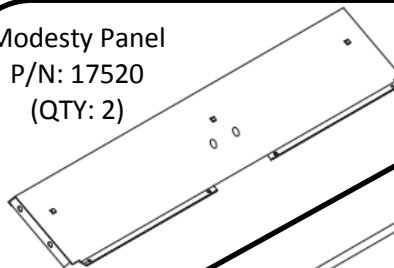

Wire Manager
P/N: 17524
(QTY: 1)

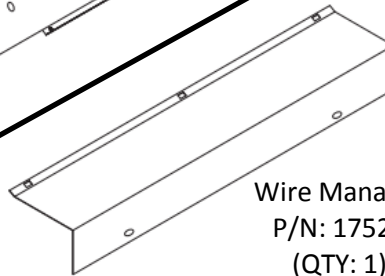

L Brackets
(Pre-attached to wire manager. Remove before assembly)

Replacement Hardware Packs:

1. 69729-R – Flex Y-Leg Hardware Pack
 1. (4) 70870 - Connector Bolt 1/4-20x23mm
 2. (4) 70871 – Connector Nut 1/4-20x17mm
 3. (2) 77817 – Allen Wrench 3/16"
 4. (17) 70054 - #10x3/4" Wood Screw
2. 69723-R – Flex Table Hardware Pack
 1. (11) 70054 - #10x3/4" Wood Screw
 2. (3) 70088 – Button Head Screw M8x20mm

For Assistance in assembling product, missing or damaged parts,
or to place an order, please contact customer service at 800-328-1061

You may also place your order online at

www.smithsystem.com

Assembly Instructions

Step 1: Loosely attach the panel to the Y-legs using (4) Connector Bolts (See Drawing 1A)

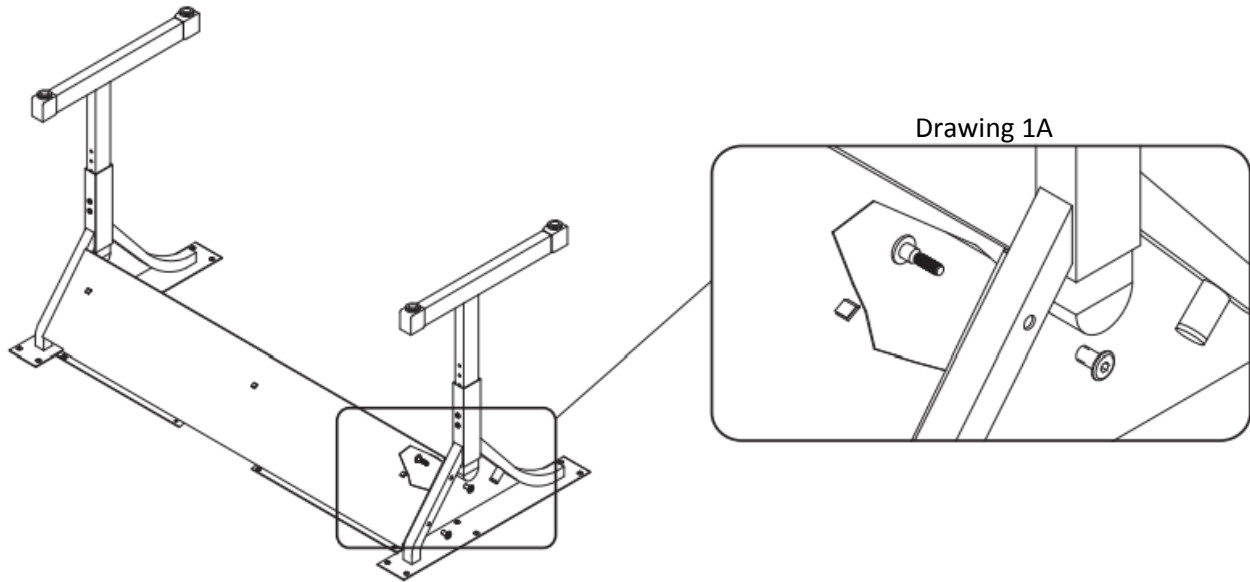

Step 2: Place the top on a smooth, clean surface with the bottom facing up. Align the frame assembly with the pilot holes and use (12) Wood Screws to attach the legs to the top (See Drawing 2A). Then attach the panel to the top using (4) Wood Screws (See Drawing 2B). Connect the "L" brackets to the top using (4) Wood Screws. Now go back and tighten the frame assembly.

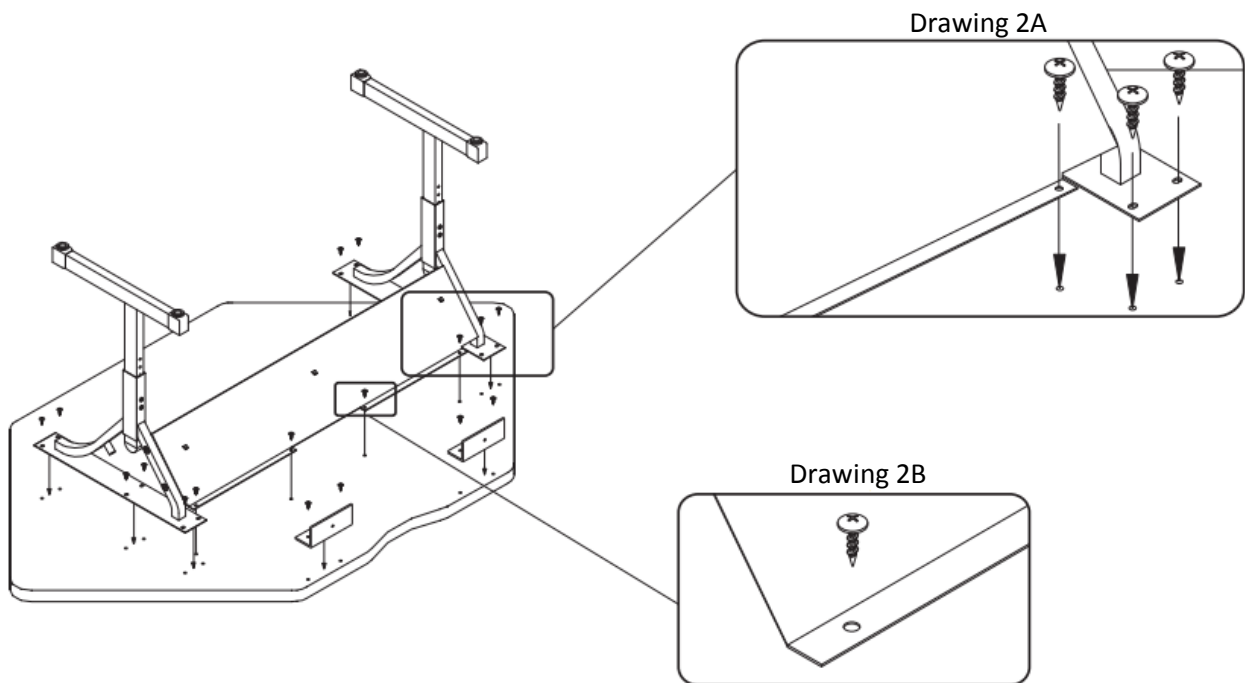

For Assistance in assembling product, missing or damaged parts,
or to place an order, please contact customer service at 800-328-1061
You may also place your order online at
www.smithsystem.com

Step 3: Place the wire manager into the hooks located at the back of the panel (See Drawing 3A). Then, use the (2) Button Head Screws to attach the wire manager to the “L” brackets (See Drawing 3B).

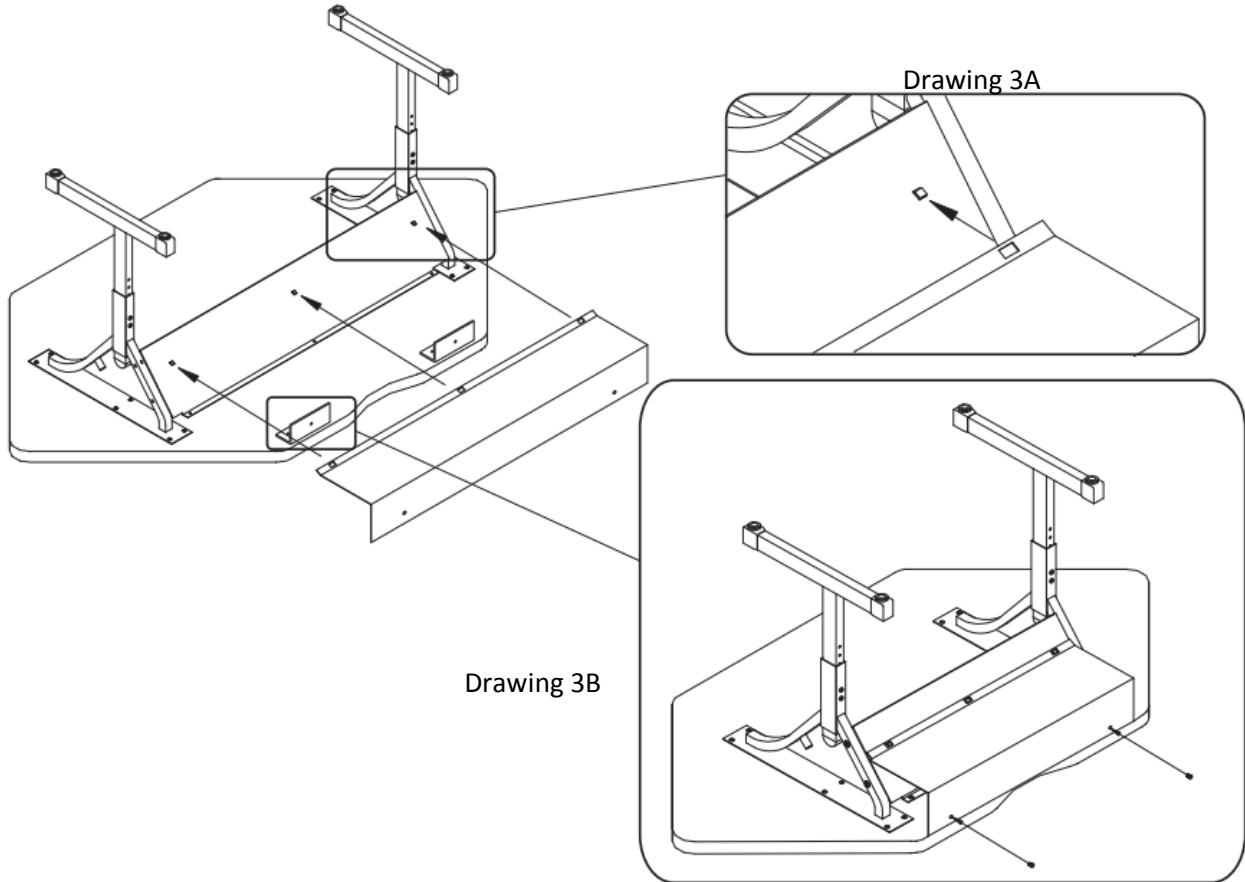

Step 4: Adjust the legs to the desired height by loosening the 3/8”-16 Dog Nut Screws and pulling out the lower part of the leg to the desired height (See Drawing 4A). Use the provided allen wrench to loosen and tighten the screws.

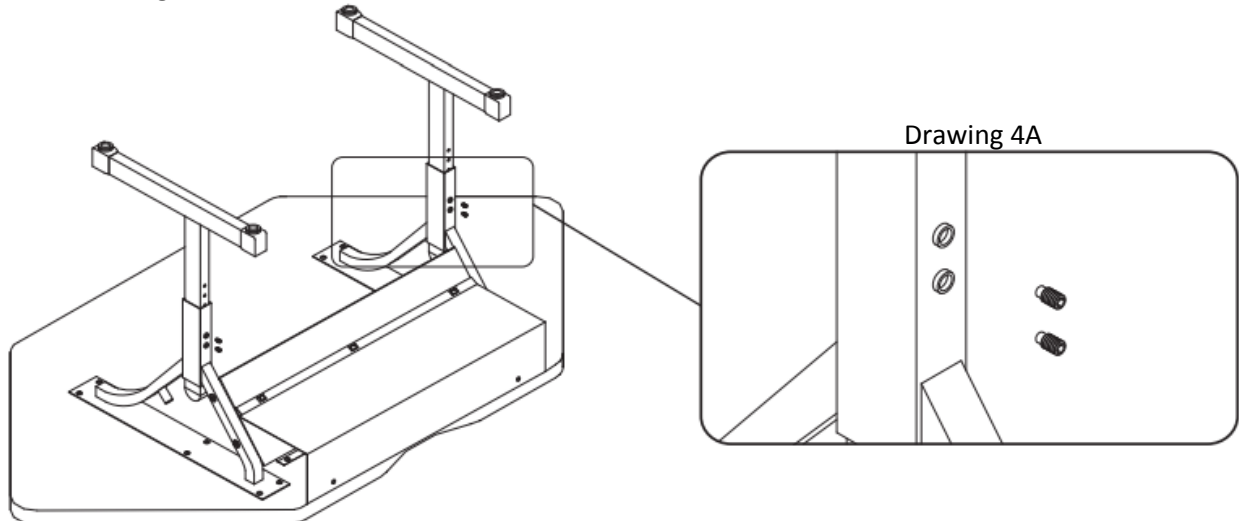

For Assistance in assembling product, missing or damaged parts,
or to place an order, please contact customer service at 800-328-1061
You may also place your order online at
www.smithsystem.com