

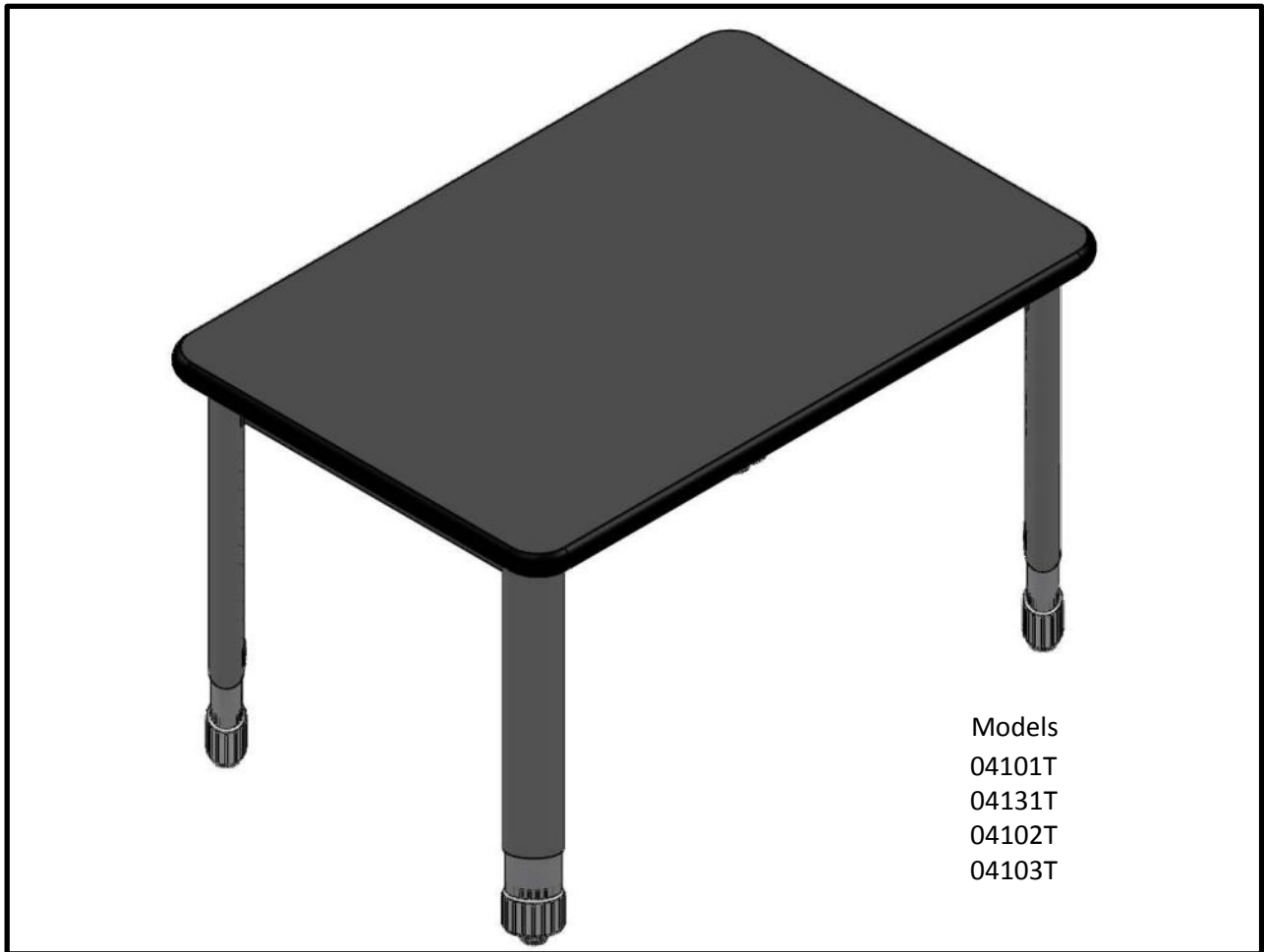

SMITH SYSTEM

Furniture for inspired learning.

Interchange Science Table Assembly Instructions (see page 5 for Trespa specifics).



SMITH SYSTEM



or to place an order, please contact customer service at 800-328-1061
You may also place your order online at
www.smithsystem.com

Hardware and Components

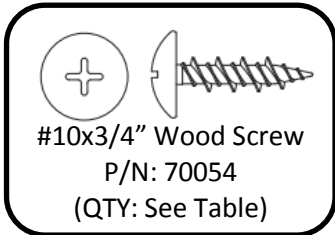
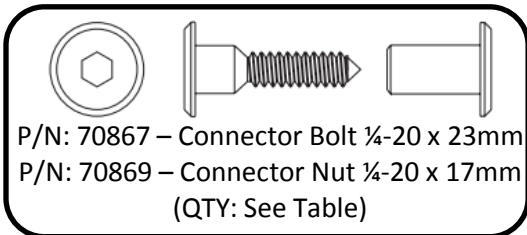
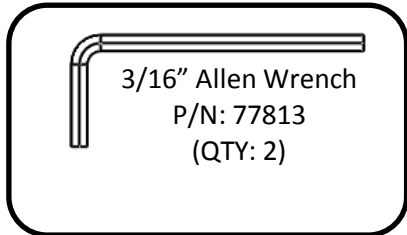
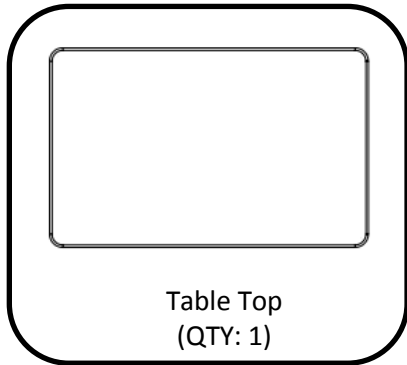
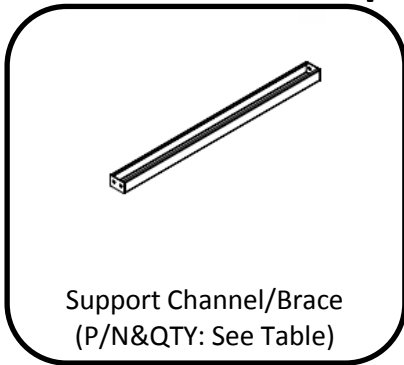
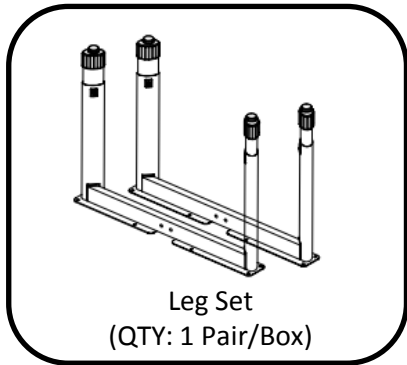

MODEL	LEG SET	BRACE	BRACE QTY	HARDWARE PACK	TOP SIZE
04100	77804	77506	1	67607	24x36
04101	77804	77508	1	67607	24x48
04102	77804	77509	1	67607	24x60
04103	77804	77510	1	67607	24x72
04104	77804	77511	1	67607	24x90
04105	77805	77506	1	67607	30x36
04106	77805	77508	1	67607	30x48
04107	77805	77509	1	67607	30x60
04108	77805	77510	1	67607	30x72
04109	77805	77511	1	67607	30x90
04110	77806	77506	1	67607	36x36
04111	77806	77508	1	67607	36x48
04112	77806	77509	1	67607	36x60
04113	77806	77510	1	67607	36x72
04114	77806	77511	1	67607	36x90
04115	77807	77507	2	67608	42x42
04116	77807	77509	2	67608	42x60
04117	77807	77510	2	67608	42x72
04118	77807	77511	2	67608	42x90
04119	77808	77508	2	67608	48x48
04121	77808	77509	2	67608	48x60
04122	77808	77510	2	67608	48x72
04123	77808	77511	2	67608	48x90
04124	77805	77505	1	67607	42 DIA
04125	77805	77506	1	67607	48 DIA
04126	77806	77508	1	67607	60 DIA
04127	77805	77507	1	67607	TRAP
04128	77805	77508	1	67607	HALF MOON
04129	77805	77508	1	67607	CONTOUR

- Replacement Hardware Packs:
1. 67607 – HDWR PK, Inter Act 24, 30, 36
 - a. (2) 77813 – 3/16" Allen Wrench
 - b. (4) 70867 - Connector Bolt ¼-20 x 23mm
 - c. (4) 70869 – Connector Nut ¼-20 x 17mm
 - d. (26) 70054 - #10x3/4" Wood Screw
 2. 67608 – HDWR PK, Inter Act 42, 48
 - a. (2) 77813 – 3/16" Allen Wrench
 - b. (8) 70867 – Connector Bolt ¼-20 x 23mm
 - c. (8) 70869 – Connector Nut ¼-20 x 17mm
 - d. (44) 70054 - #10x3/4" Wood Screw

For Assistance in assembling product, missing or damaged parts,
or to place an order, please contact customer service at 800-328-1061
You may also place your order online at

www.smithsystem.com

Assembly Instructions

Step 1: Place the top on a clean, dry surface laminate side down, so that the predrill holes face up.

Step 2a: Loosely attach the legs to the support brace using (4) connector bolts and (4) connector nuts. (See Picture #1A)

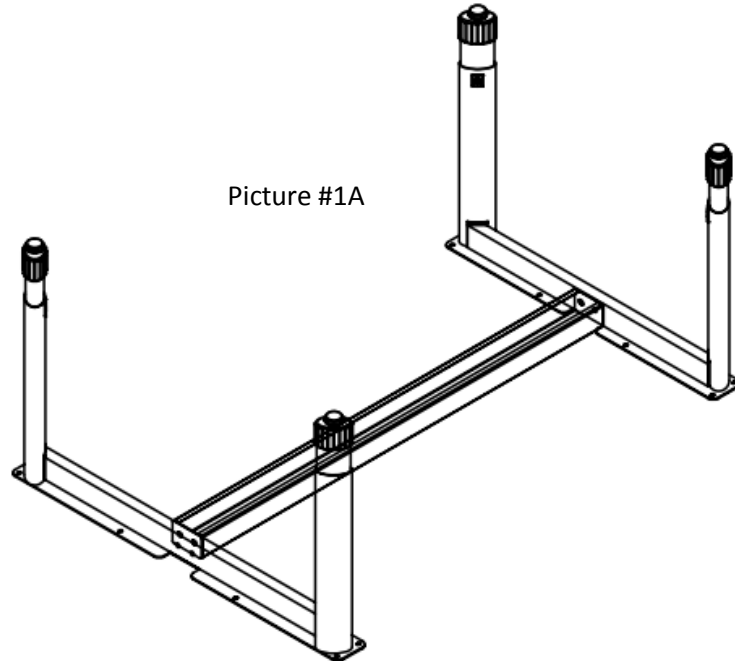

Step 2b: If your table requires a bigger assembly, attach the legs to the braces using (8) Connector Bolts and (8) connector Nuts. (See Picture #1B)

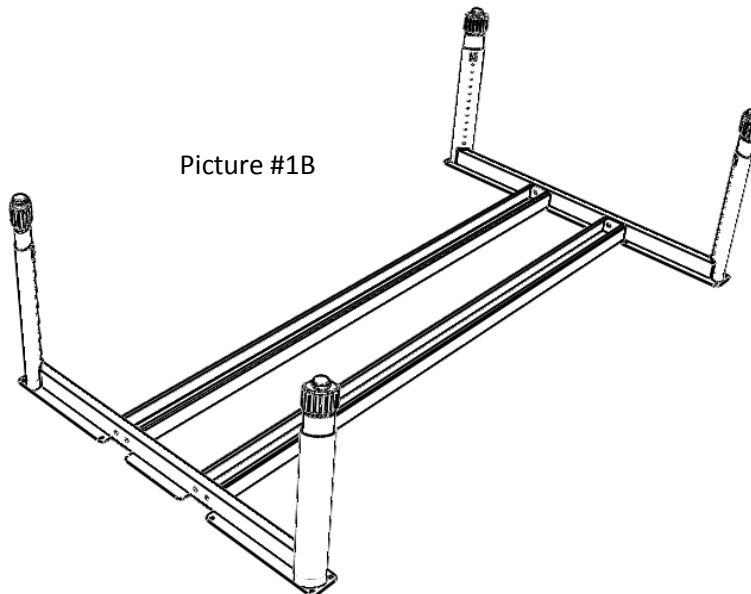

For Assistance in assembling product, missing or damaged parts,
or to place an order, please contact customer service at 800-328-1061
You may also place your order online at
www.smithsystem.com

Step 3: Align the slots of the Leg Assembly to the pre-drilled holes of the top. Using the ¾" screws provided, attach the leg assembly to the top. (Tip: Stagger the screws in the beginning. For example, Fasten one screws on one of the legs, then another screw on the other leg. Continue to stagger the screws until the assembly is attached to the top using all of the screws.

Picture #2

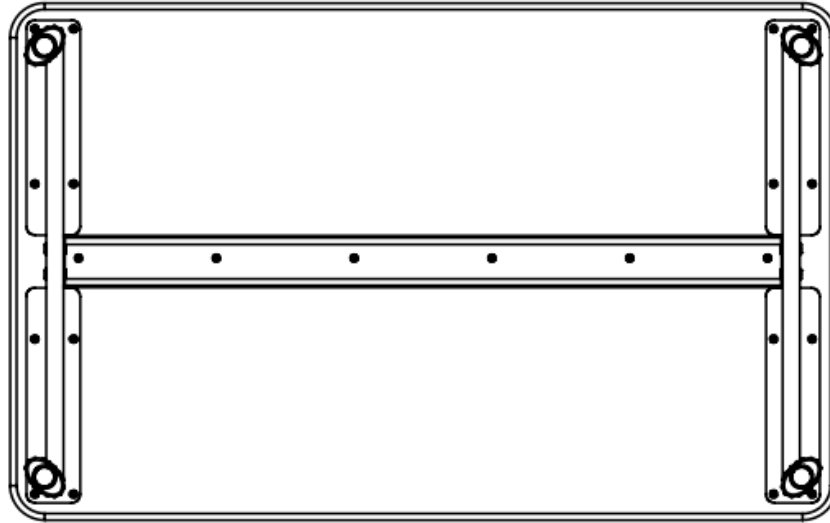

Step 4: Tighten the connector bolts and nuts to the channel, attached in Step 2, using both hex keys provided.

Step 5: Adjust the leg height as needed by loosening the set screw in the leg (use the hex key to loosen). Tighten the set screws.

Picture #3

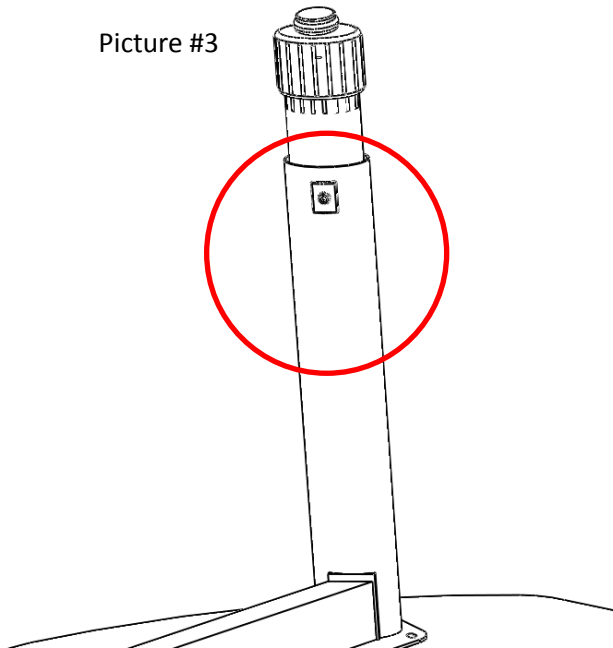

Step 6: Use the help of at least one other person and turn the table over to an upright position.

For Assistance in assembling product, missing or damaged parts,
or to place an order, please contact customer service at 800-328-1061
You may also place your order online at
www.smithsystem.com



Trespa Top Quick Installation Guide

Required for Installation

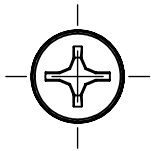

#10 x 7/16" Plastite Screw

Instructions

Step 1: Following the Instructions included with the desk frame, loosely assemble frame (finger tight).
Step 2: Flip Trespa Top over on a smooth, clean surface with the bottom facing up.
Step 3: Align the frame assembly with the pilot holes in the Trespa Top.
Step 4: Loosely install the supplied #10 Plastite screws in each of the pilot holes.
Step 5: Using the supplied Allen wrench go back and tighten bolts in frame assembly.
Step 6: Set the Torque Setting of your Drill Driver to approximately (18) or (75% of maximum). Go back and tighten all of the #10 Plastite screws being careful not to over tighten as this may cause the hole in the plastic top to strip-out. **DO NOT OVER-TORQUE**
NOTE: Because of variations in Drill Drivers you may need to reduce the Torque Setting on your particular model to prevent over tightening.

MODELS

11265 11268 11271 25705 25715 25725 25735



If you have damaged or missing components please contact customer service.

800-328-1061

www.smithsystem.com