

# mobile lectern

model #: 00502

mobile lectern with 3" casters

**DIMENSIONS & FREIGHT:**

MODEL #	D"	W"	H"	F.C.	WEIGHT
00502	17"	25"	41"	175	64 lbs.
carton	18"	26"	43"		

**OVERVIEW:**

This mobile lectern comes equipped with three storage compartments for the common instructor or speaker to use for speech materials and visual aids. Choose from 11 laminate choices, 20 edge band colors and Champagne or Black frame.

**MATERIALS:**

The 3/4" thick work surface is a thermoformed laminate and has a retaining lip to aid items from falling off. Units come fully welded and assembled, screw in the casters and they are ready to go. The spacious three storage shelves are 15"d x 20 7/8" and include 6 grommet holes for wire management. Mobile lectern features 3" diameter dual wheel casters with soft tread for quiet operation. Dual wheels have no saddle that may damage surrounding furniture.

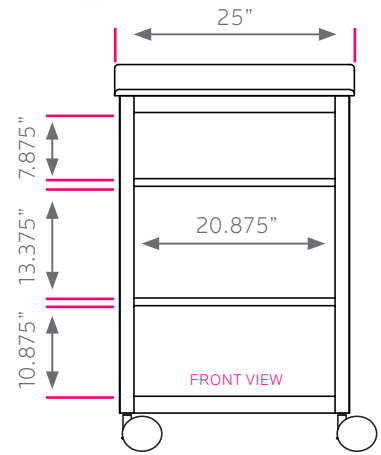
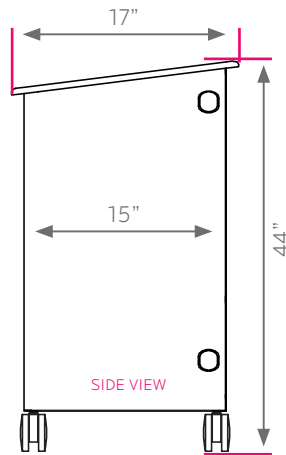
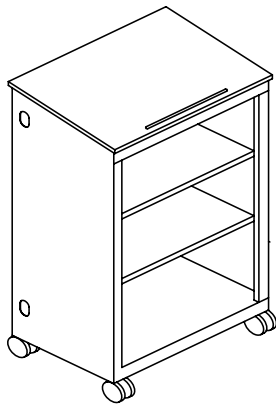

**FRAME**

- CHAMPAGNE
- BLACK

**EDGE CHOICES**

- |               |                  |                  |              |
|---------------|------------------|------------------|--------------|
| ● APPLE A     | ● CHAMPAGNE O    | ● FUCHSIA G      | ● PURPLE K   |
| ● BLACK B     | ● CHARCOAL R     | ● MINT H         | ● RED L      |
| ● BLUEBERRY C | ● CHOCOLATE Q    | ● MOCHA T        | ○ WHITE M    |
| ● BURGUNDY D  | ● CLEMENTINE E   | ● NAVY I         | ● YELLOW N   |
| ● CERULEAN S  | ● FOREST GREEN F | ● PERSIAN BLUE J | ● PLATINUM P |

**LAMINATE CHOICES**

- |                    |                   |                   |
|--------------------|-------------------|-------------------|
| ● AMBER CHERRY AME | ● GOLDEN OAK GOK  | ● PEWTER MESH PEW |
| ● ASIAN NIGHT ANG  | ● GREY MESH GRE   | ● TAN ECHO TAC    |
| ● BLOND ECHO BEE   | ● GREY NEBULA GNB | ● WILD CHERRY CHE |
| ● FUSION MAPLE MAP | ● NEW AGE OAK NEW |                   |