

# silhouette 18 x 24

29.5" fixed-height w/ caster

model #: 01603

## DIMENSIONS + FREIGHT:

MODEL #	D"	W"	H"	F.C.	CUBE	WEIGHT
01603	18"	24"	29.5"	70	1.2	36 lbs.
carton	21"	28"	7"			

\*FOR ADJUSTABLE 19"-31" H LEG SEE MODEL #01600.

## OVERVIEW:

Shipped ready to assemble, these desks have a heavy-duty work surface that won't sag under heavy books or equipment. The Silhouette Desk is great for rows, pairs, or groupings for collaborative learning.

The **WORK SURFACE** consists of a 45 lb density particle board core with a .030" high pressure laminated surface and a .020" melamine backer sheet. The edge of the work surface features 3/8" bumper edge molding that is fastened every 6 to 8 inches to assure a long lasting fit. The frame is attached to the pre-drilled holes in the top with (6) #10 screws through a 1" x 1.75" 18-gauge steel channel. The mounting channel is welded to a 1" x 2" rectangular 16-gauge steel tube leg. The leg inserts are 1" x 1.75" 16-gauge steel tube and are fixed in height at 29.5".

The legs are tied together for added strength with a 1" x 2" 16-gauge steel tube stretcher bar and (4) bolts. Legs have 3" dual-wheel casters standard. Book Box is optional (Model 17190), all welded 22-gauge steel construction that has a curled hem on the front opening. Book box comes in a BLACK powdercoat finish, or Platinum is special order only. **\*Book box sold separately.**

## SILHOUETTE TOP & EDGE PROFILE

1 1/4" TOP

3/4" TOP

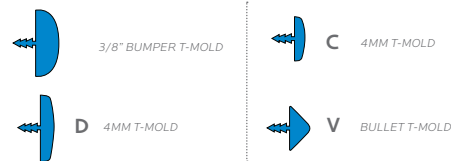

## OPTIONAL ACCESSORIES

MODEL #		D"	W"	H"	F.C.	CUBE	WEIGHT
17190	steel bookbox	15"	20"	4"	70	3.0	8 lbs.
17200	wire book-basket	15"	18"	3.5"	70	3.0	5 lbs.
30925	SW tray w/ housing	16.8"	13.5"	3"	70	1.2	8 lbs.
30926	EW tray w/ housing	16.8"	19.6"	3"	70	1.2	10 lbs.
17576	3" casters, set of 4			3"	70	0.1	5 lbs.



\*MODEL 01602 SHOWN (FIXED-HEIGHT 29.5" LEG WITH GLIDE)

3" CASTERS (#17576) INCLUDED WITH #01603

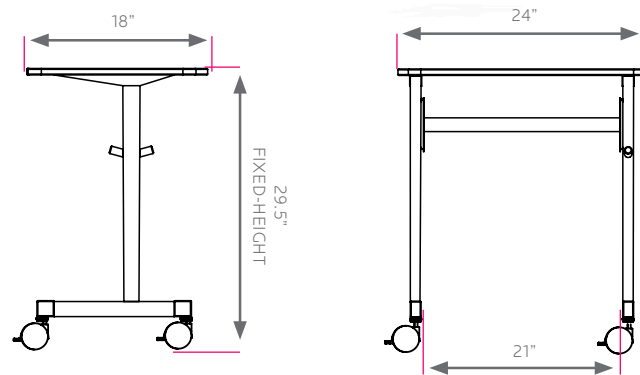

## FRAME

- BLACK
- PLATINUM

## EDGE CHOICES

- APPLE
- BLACK
- BLUEBERRY
- BURGUNDY
- CERULEAN
- ORANGE
- CHAMPAGNE
- CHARCOAL
- CHOCOLATE
- CLEMENTINE
- FOREST GREEN
- FUCHSIA
- MINT
- MOCHA
- NAVY
- PERSIAN BLUE
- PURPLE
- RED
- WHITE
- YELLOW
- PLATINUM

## LAMINATE CHOICES

- AMBER CHERRY
- ASIAN NIGHT
- BLOND ECHO
- FUSION MAPLE
- GOLDEN OAK
- GREY MESH
- GREY NEBULA
- NEW AGE OAK
- PEWTER MESH
- TAN ECHO
- WILD CHERRY