

projector lectern

model #: 04620

projector lectern

DIMENSIONS & FREIGHT:

MODEL #	D"	W"	H"	F.C.	WEIGHT
04620	18"	30"	28"	85	78 lbs.
carton	22"	32.5"	31"		

OVERVIEW:

This projector lectern comes equipped with two storage compartments, which makes a strong statement in classrooms, libraries, meeting rooms and more.

MATERIALS:

Units come fully welded and assembled, just screw in the casters and they are ready to go. The projector area accommodates digital and over-head projectors. Also included is our 18" x 20" lectern, that can be positioned on the right or left. The Projector area includes a rubber mat to steady equipment. The spacious two storage shelves are 18"d x 30"w and includes 6 grommet holes for wire management. Mobile lecterns feature 3" diameter dual wheel casters with soft tread for quiet operation. Dual wheels have no saddle that may damage surrounding furniture.

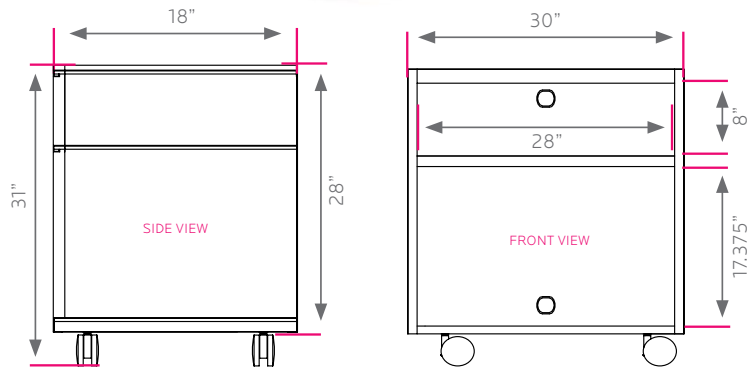
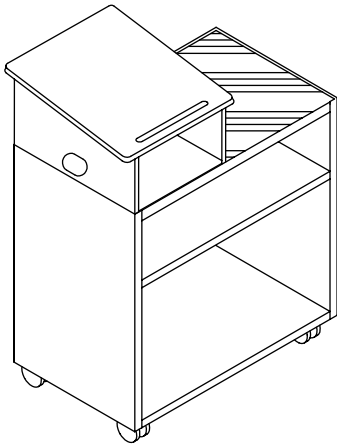

FRAME

- CHAMPAGNE
- BLACK

EDGE CHOICES

- | | | | |
|---------------|------------------|------------------|--------------|
| ● APPLE A | ● CHAMPAGNE O | ● FUCHSIA G | ● PURPLE K |
| ● BLACK B | ● CHARCOAL R | ● MINT H | ● RED L |
| ● BLUEBERRY C | ● CHOCOLATE Q | ● MOCHA T | ○ WHITE M |
| ● BURGUNDY D | ● CLEMENTINE E | ● NAVY I | ● YELLOW N |
| ● CERULEAN S | ● FOREST GREEN F | ● PERSIAN BLUE J | ● PLATINUM P |

LAMINATE CHOICES

- | | | |
|--------------------|-------------------|-------------------|
| ● AMBER CHERRY AME | ● GOLDEN OAK GOK | ● PEWTER MESH PEW |
| ● ASIAN NIGHT ANG | ● GREY MESH GRE | ● TAN ECHO TAC |
| ● BLOND ECHO BEE | ● GREY NEBULA GNB | ● WILD CHERRY CHE |
| ● FUSION MAPLE MAP | ● NEW AGE OAK NEW | |