

# booktruck, six sloping shelf

model #: 21001

## six sloping shelf booktruck

### DIMENSIONS & FREIGHT:

MODEL #	D"	W"	H"	F.C.	WEIGHT
21001	18"	36"	43"	150	73 lbs.
carton	19"	37.5"	40"		

### OVERVIEW:

Smith System™ Book Trucks are a handy companion to the library or classroom, carrying up to 400 lb of books, paper and projects. They move easily through aisles on soft-tread, dual wheel casters that won't shimmy like single wheels.

### MATERIALS:

Smith System™ Book Truck #21001 consists of (2) Frames, (2) End Panels and (3) Sloping Shelf Weldments. The End Panels consist of 20-gauge steel full height panels welded to 1" square 18-gauge steel tubing Frame with formed in handles that radius for added comfort and ease of movement. The Shelves are constructed of 20-gauge steel double sided sloping shelves that are 34" long and 7 3/4" deep on each side and a 6" high back. The shelves sport a 12 3/4" clearance between shelves and are welded to the frames and end panels of the Book Truck. All Book Trucks feature 4" diameter dual wheel casters with soft tread for quiet operation. Dual wheels have no saddle that may damage surrounding furniture.



\*shown with optional book supports/dividers #21104.

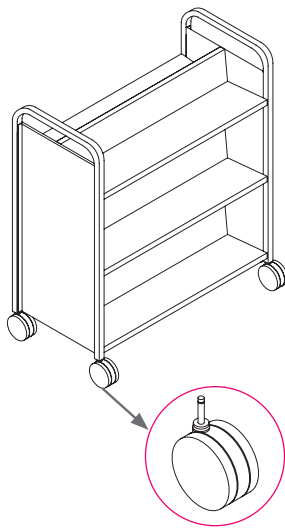

4" DIA. CASTERS

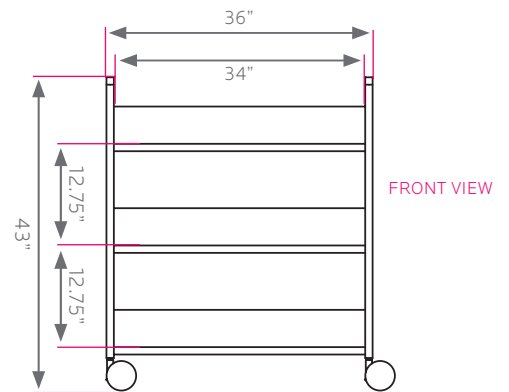
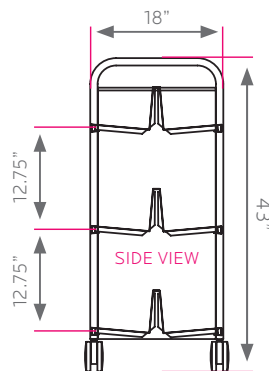
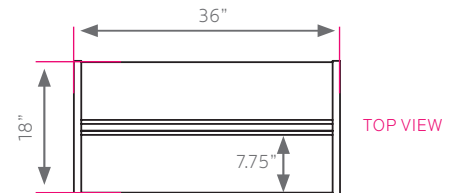

### BOOKTRUCK COLOR CHOICE

- APPLE
- BLACK
- BLUEBERRY
- BURGUNDY
- CERULEAN
- CHAMPAGNE
- CHOCOLATE
- CLEMENTINE
- FOREST GREEN
- FUCHSIA
- MINT
- MOCHA
- NAVY
- PERSIAN BLUE
- PURPLE
- RED
- SAND
- YELLOW
- PLATINUM