

# booktruck, three flat shelves

model #: 21051

36" w, three flat shelf booktruck

**DIMENSIONS & FREIGHT:**

MODEL #	D"	W"	H"	F.C.	WEIGHT
21051	18"	36"	43"	150	62 lbs.
carton	19"	37.5"	40"		

**OVERVIEW:**

Smith System™ Book Trucks are a handy companion to the library or classroom, carrying up to 400 lb of books, paper and projects. They move easily through aisles on soft-tread, dual wheel casters that won't shimmy like single wheels.

**MATERIALS:**

Smith System™ Book Truck #21051 consists of (2) Frames, (2) End Panels, and (2) Sloping Shelf Weldments and (3) Flat Shelves. The End Panels consist of 20-gauge steel full height panels welded to 1" square 18-gauge steel tubing Frame with formed in handles that radius for added comfort and ease of movement. The Shelves are constructed of 20-gauge steel that is 34" long x 17 9/16" deep x 1" high edge. The shelves sport a 12 3/4" clearance between shelves and are welded to the frames and end panels of the Book Truck. All Book Trucks feature 4" diameter dual wheel casters with soft tread for quiet operation. Dual wheels have no saddle that may damage surrounding furniture.

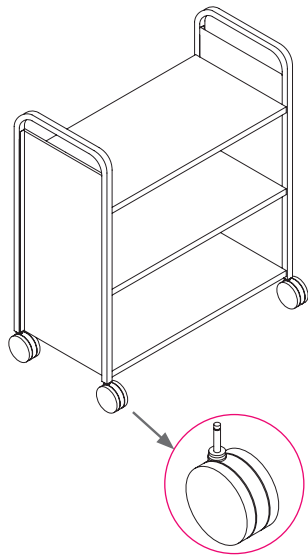
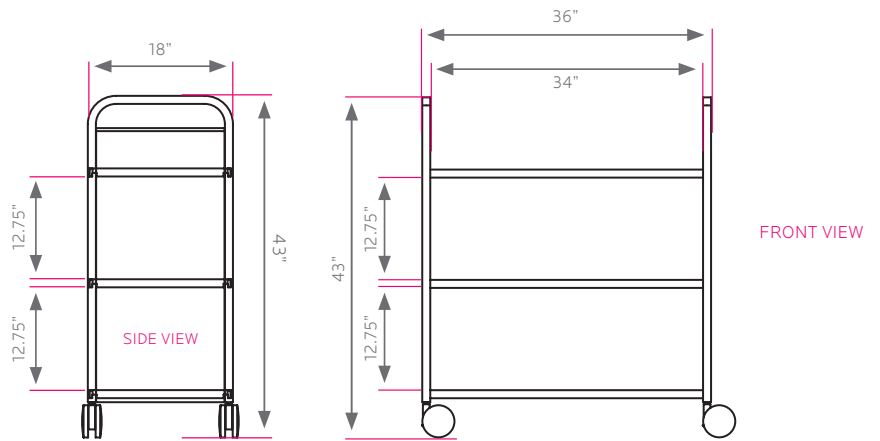
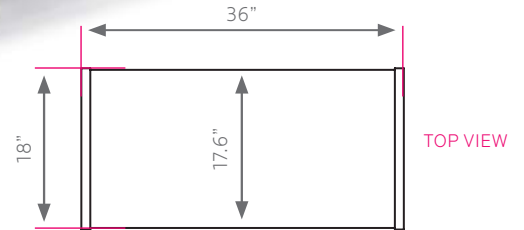

4" DIA. CASTERS

**BOOKTRUCK COLOR CHOICE**

- APPLE
- BLACK
- BLUEBERRY
- BURGUNDY
- CERULEAN
- CHAMPAGNE
- CHOCOLATE
- CLEMENTINE
- FOREST GREEN
- FUCHSIA
- MINT
- MOCHA
- NAVY
- PERSIAN BLUE
- PURPLE
- RED
- SAND
- YELLOW
- PLATINUM