

gorilla truck, 3 flat shelves

model #: 21103

gorilla booktruck, 3 flat shelves

DIMENSIONS & FREIGHT:

| MODEL # | D" | W" | H" | F.C. | WEIGHT |
|---------|-----|-------|-----|------|---------|
| 21103 | 18" | 36" | 44" | 150 | 78 lbs. |
| carton | 19" | 37.5" | 40" | | |

OVERVIEW:

Smith System™ Book Trucks are a handy companion to the library or classroom, carrying up to 600 lb of books, paper and projects. Fixed middle casters make it easy for the truck to pivot on an axis which makes it great for getting over thresholds. Comes standard with dual wheel casters, 5", that won't shimmy like single wheel casters.

MATERIALS:

Smith System™ Book Truck #21103 consists of (2) Frames, (2) End Panels, and (2) Sloping Shelf Weldments and (3) Flat Shelves. The End Panels consist of 20-gauge steel full height panels welded to 1" square 18-gauge steel tubing Frame with formed in handles that radius for added comfort and ease of movement. The Shelves are constructed of 20-gauge steel that is 34" long x 17 9/16" deep x 1" high edge. The shelves sport a 12 3/4" clearance between shelves and are welded to the frames and end panels of the Book Truck. Gorilla Book Trucks feature 5" diameter dual wheel casters with soft tread, which also includes a six-wheel construction for easy maneuverability. Dual wheels have no saddle that may damage surrounding furniture.

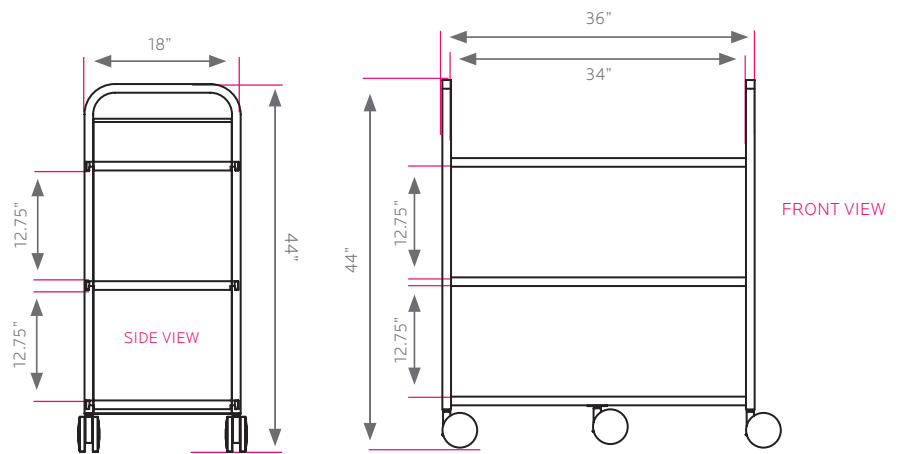
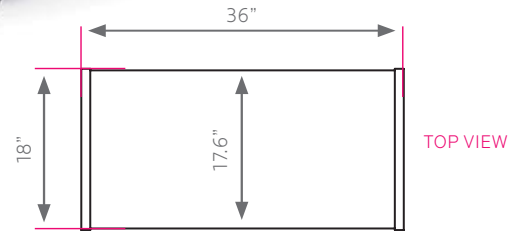

BOOKTRUCK COLOR CHOICE

- APPLE
- BLACK
- BLUEBERRY
- BURGUNDY
- CERULEAN
- CHAMPAGNE
- CHOCOLATE
- CLEMENTINE
- FOREST GREEN
- FUCHSIA
- MINT
- MOCHA
- NAVY
- PERSIAN BLUE
- PURPLE
- RED
- SAND
- YELLOW
- PLATINUM