

uxl 60" trapezoid



• UXL Tables are standard with a 3/4" Bullet T-Mold top and fixed-height legs (FL).

model #: XL60TR_..._PLTFL

uxl 60" trapezoid

DIMENSIONS + FREIGHT:

| MODEL # | D" | W" | H" | F.C. | CUBE | WEIGHT |
|---------|--------|-----|-------|------|------|---------|
| XL60TR | 30" | 60" | 29.5" | 70 | 2.8 | 90 lbs. |
| carton | 31.13" | 63" | 3.13" | | | |

OVERVIEW:

The UXL line offers high schools and colleges a complete, integrated system for outfitting the entire school, from classrooms to commons.

MATERIALS:

The 3/4" or 1 1/4" thick **WORK SURFACE** consists of a 45 lb density particle board core with a 0.030" high pressure laminated surface and a 0.020" melamine backer sheet. The edge of the work surface features edge molding that is mechanically fastened to the underside of the work surface every 6 to 8 inches to assure a long lasting fit.

The frame is attached to the pre-drilled holes in the top with #10 x 5/8" screws. The legs then fasten into the frame at each corner. The frame comes fully assembled requiring only two bolts per leg to complete installation. The table frame is a boxed tube design made of aircraft grade aluminum to reduce weight, while being very stable and sturdy. The 16-gauge steel legs are 2" diameter and powder coated for a long lasting durable finish. Legs are available in different configurations, see chart.



*XL72TR, 36" x 72" Trapezoid shown with 18"h Intuit Stack Chairs model #00509.

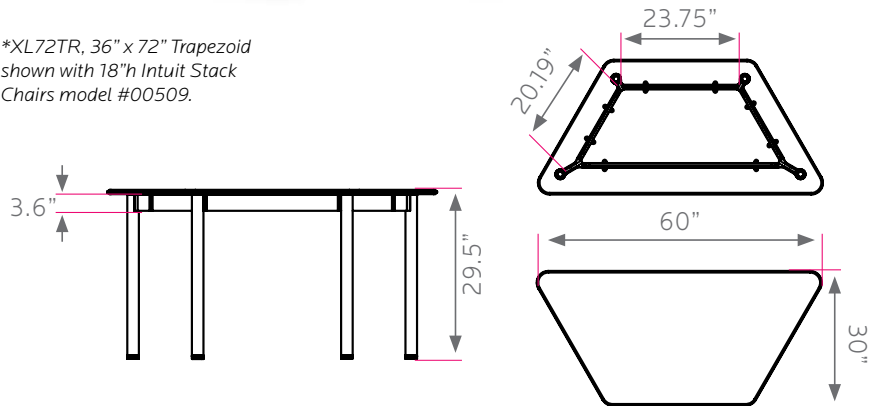

UXL LEG OPTIONS

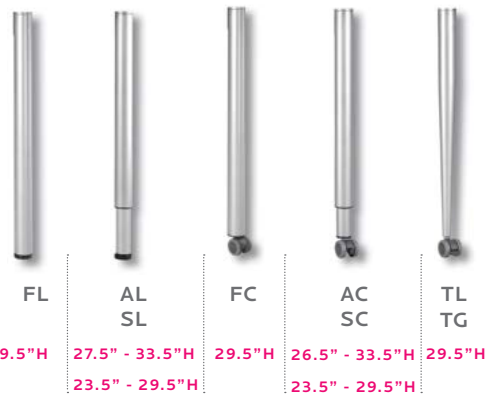

FRAME

● PLATINUM **PLT**

Choose MODEL **7 8 9 10** PLT FL
 Pick Laminate Color Pick Edge Color
 Fixed-height (FL) leg set is standard. See page 99 to order optional leg sets.

EDGE CHOICES

- APPLE **A**
- BLACK **B**
- BLUEBERRY **C**
- BURGUNDY **D**
- CERULEAN **S**
- ORANGE **U**
- CHAMPAGNE **O**
- CHARCOAL **R**
- CHOCOLATE **Q**
- CLEMENTINE **E**
- FOREST GREEN **F**
- FUCHSIA **G**
- MINT **H**
- MOCHA **T**
- NAVY **I**
- PERSIAN BLUE **J**
- PURPLE **K**
- RED **L**
- WHITE **M**
- YELLOW **N**
- PLATINUM **P**

UXL TOP & EDGE PROFILE

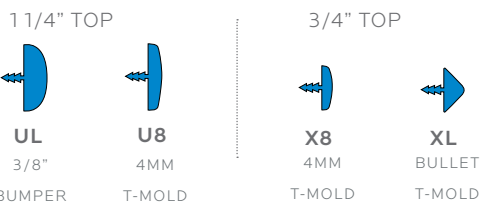

LAMINATE CHOICES

- AMBER CHERRY **AME**
- ASIAN NIGHT **ANG**
- BLOND ECHO **BEE**
- FUSION MAPLE **MAP**
- GOLDEN OAK **GOK**
- GREY MESH **GRE**
- GREY NEBULA **GNB**
- NEW AGE OAK **NEW**
- PEWTER MESH **PEW**
- TAN ECHO **TAC**
- WILD CHERRY **CHE**