

planner lab corner station

model #: 24600

planner lab corner station

DIMENSIONS + FREIGHT:

MODEL #	D"	W"	H"	F.C.	CUBE	WEIGHT
24600	30"	48"	22" - 32"	70	5.8	114 lbs.

OVERVIEW:

Planner Lab corner stations allow your computer lab to wrap into the corners of your classroom. The desk is built with Planner™ strength and stability. Manages cables while providing a snug fit against both walls.

The **WORK SURFACE** consists of a 1 1/4" thick, 45 lb density particle board core with a 0.030" high pressure laminated surface and a 0.020" backer sheet. The edge of the work surface features T-mold that is stapled to the underside of the work surface every 6"-8". The **LEG SYSTEM** is attached to the pre-drilled holes in the top with (12) #10 x 3/4" screws through a 3 1/8"W x 18"L 14-gauge steel mounting plate. The mounting plate is welded to (2) 1 1/4" square 14-gauge steel tube legs which is welded to a 1" square 14-gauge steel tube cross bar. The leg inserts are 1" square 14-gauge steel tube and adjust in height from 22" to 32" in 1" increments. The adjustment for each leg is secured with (2) 3/8" - 16 x .675" Allen screws. The right and left leg both include the Smith System patented **BACKPACK PEG** allowing for either inside or outside positioning. The legs are tied together for added strength with a 6" high 18-gauge steel panel and four connector bolts. Legs have 1" adjusting leveling glides. A **WIRE BASKET** that mounts under the work surface is included for wire management.



Model 24600 Planner Lab Corner Station in Maple top, Black edge and Platinum frame.

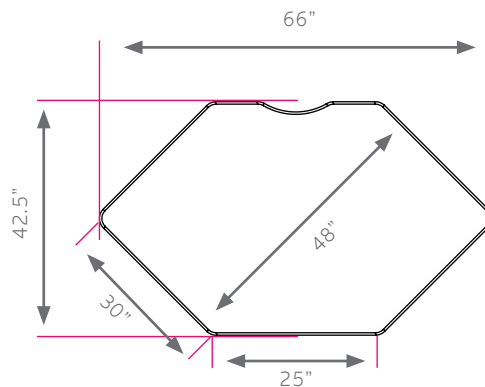

Make it mobile with 3" casters
Order Model 17576

PLANNER TOP & EDGE PROFILE

1 1/4" TOP

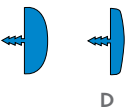

OPTIONAL ACCESSORIES



#17350 MONITOR MOUNT

FRAME

- BLACK
- PLATINUM

EDGE CHOICES

- APPLE
- CHAMPAGNE
- FUCHSIA
- PURPLE
- BLACK
- CHARCOAL
- MINT
- RED
- BLUEBERRY
- CHOCOLATE
- MOCHA
- WHITE
- BURGUNDY
- CLEMENTINE
- NAVY
- YELLOW
- CERULEAN
- FOREST GREEN
- PERSIAN BLUE
- PLATINUM
- ORANGE

LAMINATE CHOICES

- AMBER CHERRY
- GOLDEN OAK
- PEWTER MESH
- ASIAN NIGHT
- GREY MESH
- TAN ECHO
- BLOND ECHO
- GREY NEBULA
- WILD CHERRY
- FUSION MAPLE
- NEW AGE OAK

