

uxl foldaway tablet chair

model #: XL183P_P_NF & XL183P_P_FN

uxl foldaway tablet chair, right & left

DIMENSIONS + FREIGHT:

MODEL #		D"	W"	H"	F.C.	WEIGHT
XL183P_P_NF	right-hand	29	22.5	18	125	19 lbs.
XL183P_P_FN	left-hand	29	22.5	18	125	19 lbs.

MATERIALS:

The **CHAIR FRAME** is 0.59" x 1.18" x 0.078" thick DD oval shaped cold rolled steel tube and 0.75" diameter x 0.078" thick round steel tube fully welded with a platinum powdercoat paint finish.

The **BACKREST AND SEAT** are made of 100% virgin polypropylene material with high impact strength. The Backrest is supported with a metal bar insert that provides very strong support. Backrest and seat available in 17 colors.

The **FOLDAWAY WRITING TABLET** is made of ABS plastic and is equipped with a dual angle position foldaway armrest mechanism. The tablet, when fixed to the armrest has a unique mechanism that allows easy upward and downward motion. The dimension of the tablet is 11"d x 17"w x 3/4" thick. Both the armrest and the foldaway tablet come in a left and a right hand model. The armrest is attached to the chair and then the foldaway tablet is easily attached to the arm rest with an Allen screw.

The Aluminum Armrest is made of aluminum alloy with top cover in ABS plastic, black.

OPTIONS:

Add a **UXL BOOKBASKET, #77930 PLT** to a UXL Foldaway Tablet Chair for a convenient storage solution for the classroom.



#77930 PLT

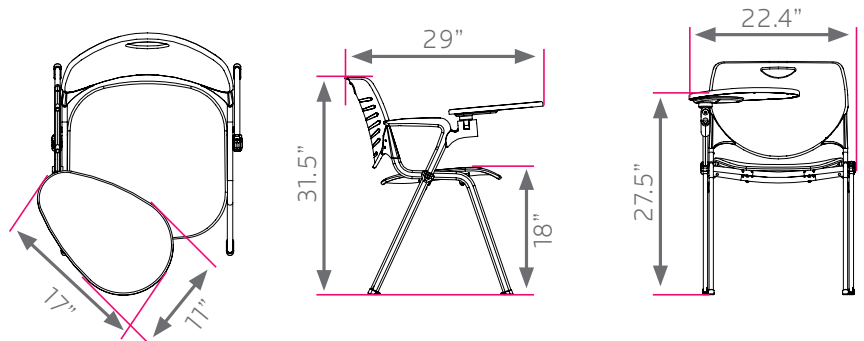

UXL SEAT & BACK COLOR CHOICE Seat Color Choice for 1st Choose 1 letter Back Color Choice for 2nd Choose 1 letter **FRAME**

- Apple **A**
- Burgundy **D**
- Chocolate **Q**
- Fuchsia **G**
- Navy **I**
- Red **L**
- Black **B**
- Cerulean **S**
- Clementine **E**
- Mint **H**
- Persian Blue **J**
- White* **M**
- Blueberry **C**
- Charcoal* **R**
- Forest Green **F**
- Mocha **T**
- Purple **K**
- Yellow **N**

 Platinum

* White and Charcoal available in poly only. Charcoal in 18" only.