

ASSEMBLY INSTRUCTIONS

ACROBAT™

BULLET, RECTANGLE, PENINSULA & CONTOUR

Rectangle Workstations

26443	Rectangle Instructor Desk 30" x 48"
26453	Rectangle Instructor Desk 30" x 60"
26526	Rectangle Instructor Desk 30" x 72"
26528	Rectangle Instructor Desk 30" x 60" w/ BBF Pedestal

Peninsula Workstations

26213	Peninsula Instructor Desk 36" x 72"
26233	Peninsula Instructor Desk 36" x 60"

Bullet Workstations

26515	Bullet Workstation 24" x 45"
26512	Bullet Workstation 30" x 45"
26516	Bullet Workstation 30" x 60"
26522	Bullet Workstation 30" x 72"
26536	Bullet Instructor Desk 30" x 60" (w/ BBF Ped + Lectern)
26538	Bullet Instructor Desk 30" x 72" (w/ BBF Ped + Lectern)

Contour Workstations

26203	Contour Instructor Desk 36" x 72"
26223	Contour Instructor Desk 36" x 60"

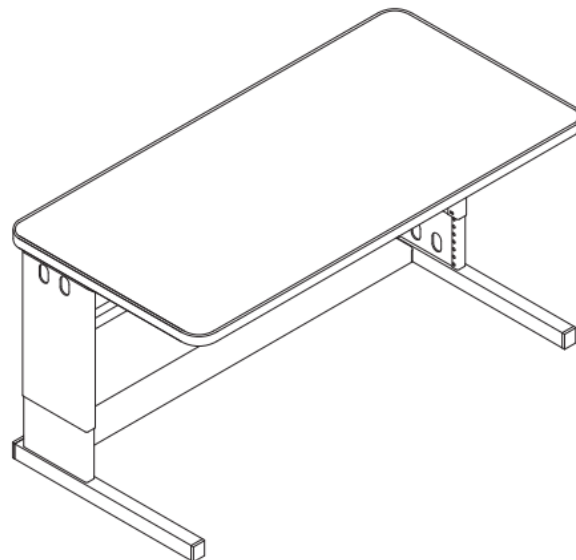

*For assistance in assembling product, missing or damaged parts,
or to place an order, please contact Customer Service at 800-328-1061.*

Bullet Desk

Rectangle Desk

Peninsula Desk

Contour Desk

FURNITURE FOR INSPIRED LEARNING.®



SMITH SYSTEM®

HARDWARE AND COMPONENTS

* a phillips head screw driver will be needed for assembly.

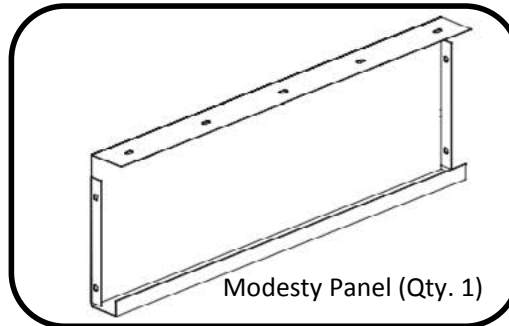
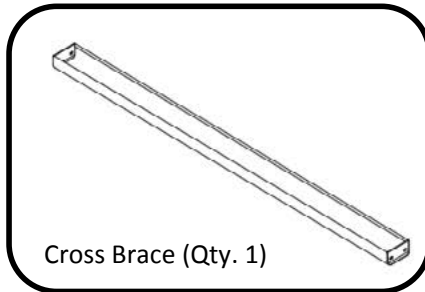
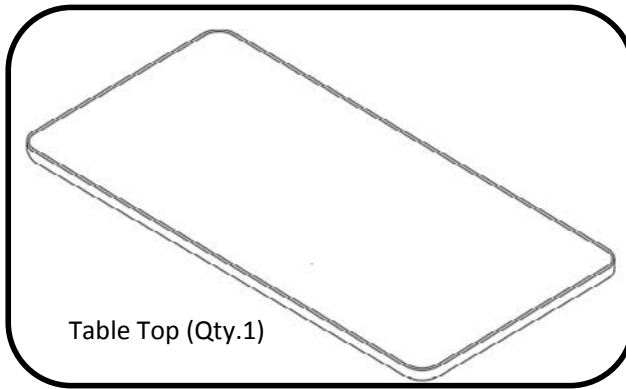
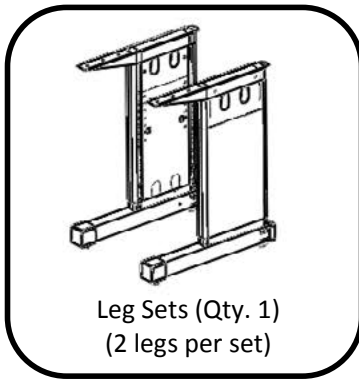
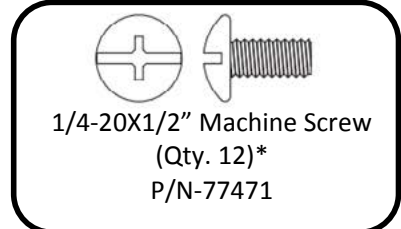
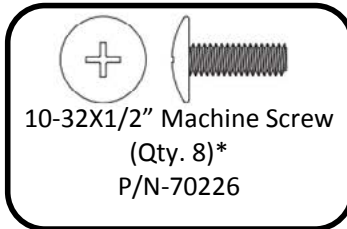
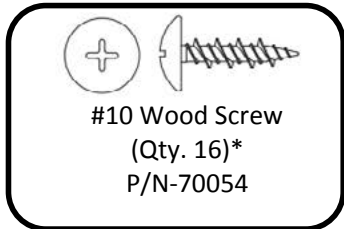

* the Acrobat Workstations come in different lengths and shapes; so hardware and screw hole placement will vary. If you feel you have not received all of the necessary hardware, please contact Customer Service.

ACROBAT™ WORKSTATION REPLACEMENT HARDWARE PACK

[1] 69755 HARDWARE PACK, ACROBAT WORKSTATIONS

QTY 16	#77471 - 1/4 - 20 X 1/2" COMBO DRIVE MACHINE SCREW
QTY 8	#70226 - 10 - 32 X 1/2" MACHINE SCREW
QTY 2	#77482 - TINNERMAN CLIP
QTY 16	#70054 - #10 X 3/4" WOOD SCREW HI/LO PTH

ASSEMBLY INSTRUCTIONS

STEP 1: Flip the top upside down on a clean dry surface. Align the leg sets with the predrilled holes on the top.

STEP 2: Adjust the legs to the desired height by taking out the (4) 1/4 - 20 x 1/2" machine screws per leg and reinserting them at the desired height.

2A: Install (1) Tinnerman clip per leg in the square hole located inside the leg.

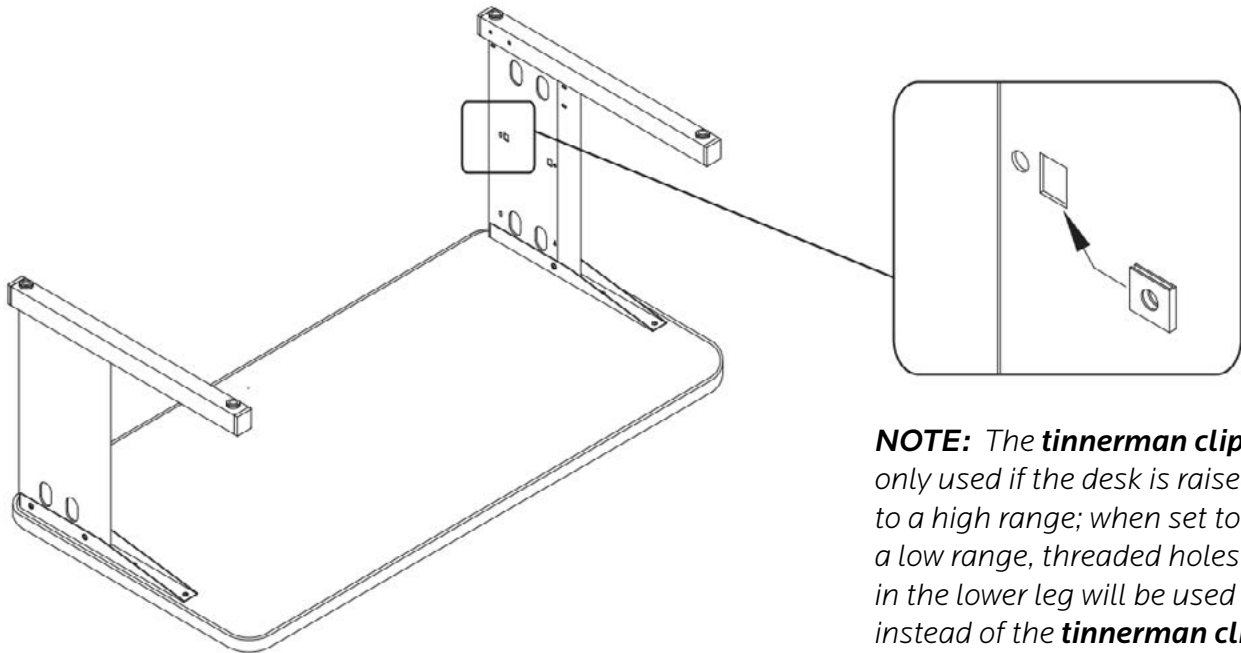

NOTE: The **tinnerman clip** is only used if the desk is raised to a high range; when set to a low range, threaded holes in the lower leg will be used instead of the **tinnerman clip**.

ASSEMBLY INSTRUCTIONS

STEP 3: Attach the modesty panel to the legs using (4) 1/4 - 20 x 1/2" machine screws.
(The 1/4 - 20 screws for the height of the leg set may need to be loosened to realign holes to attach the modesty panel).

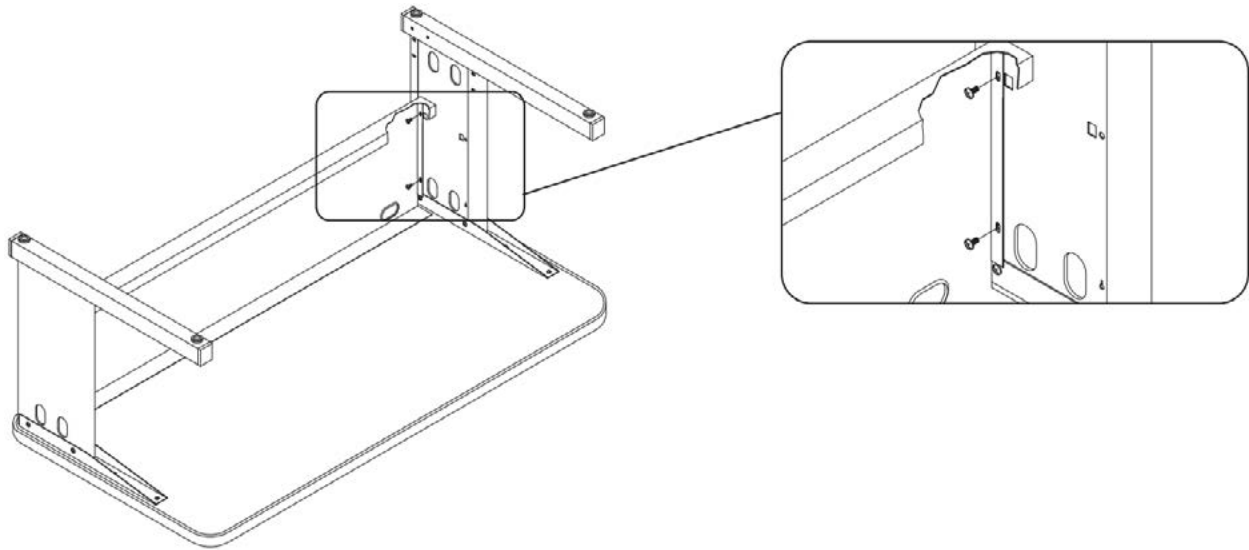

STEP 4: Attach the cross brace to the foot using the (4) 10 - 32 x 1/2" machine screws.

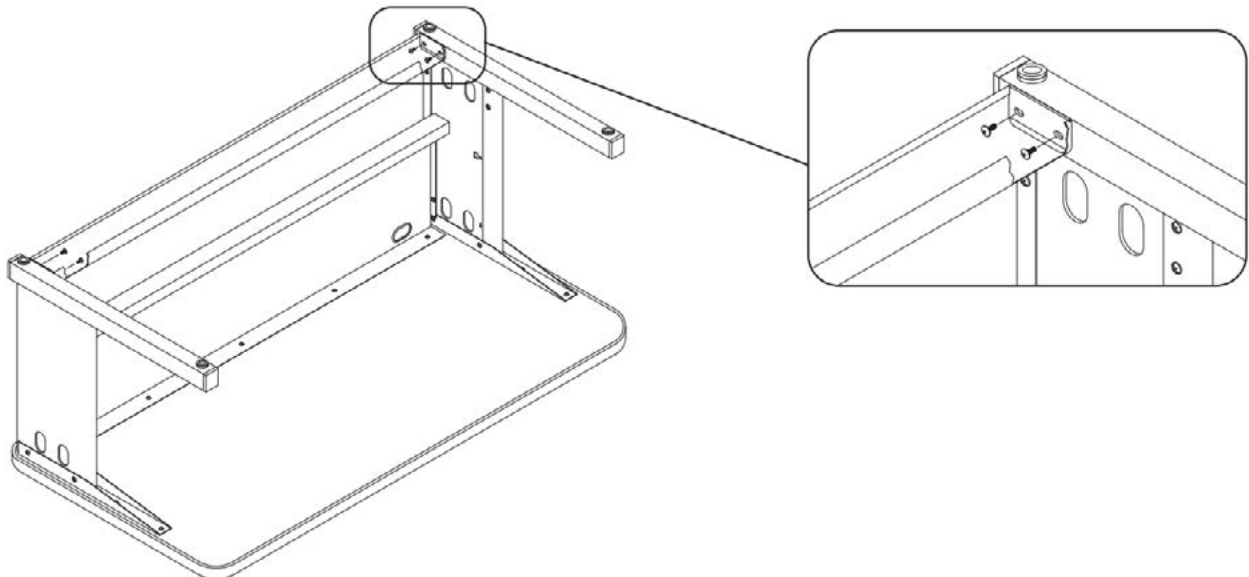

ASSEMBLY INSTRUCTIONS

STEP 5: Attach the brackets to the top using (8) #10 wood screws, by first aligning the brackets with the predrilled holes in the top.

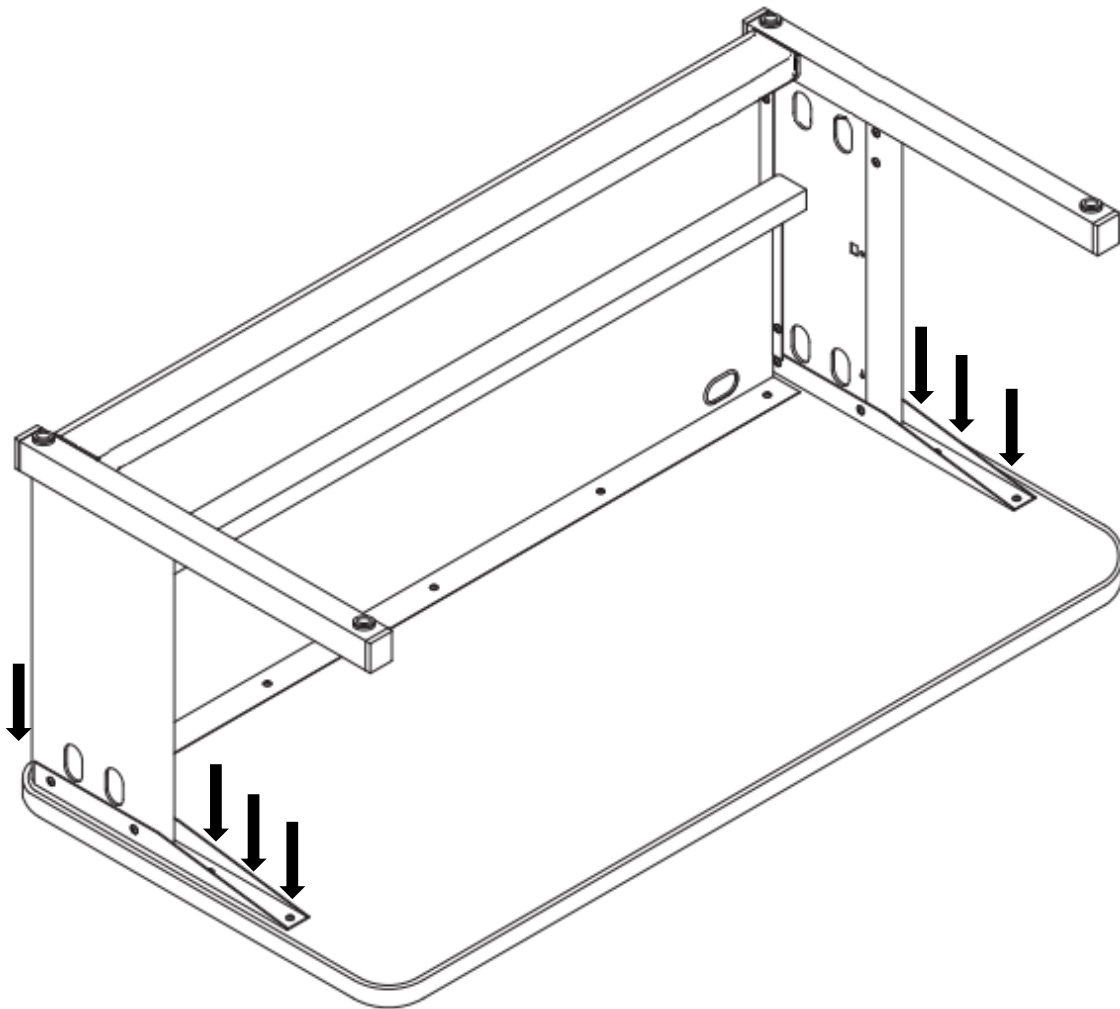

STEP 6: With the help of another person, flip the desk back into its upright position. Your desk is now ready for use. Enjoy!