

booktruck, everything cart

model #: 21088

everything cart, 2 shelves w/ 6 bins each

DIMENSIONS & FREIGHT:

MODEL #	D"	W"	H"	F.C.	WEIGHT
21088	18"	36"	36"	150	70 lbs.
carton	19"	37.5"	33.5"		

OVERVIEW:

The Everything™ Cart has two levels of double-face bins that can hold almost anything from books to art supplies, gym equipment and student works. They move easily through aisles on soft-tread dual wheel casters that won't shimmy like single wheels.

MATERIALS:

Units come fully welded and assembled, just pop in the casters and they are ready to go. Everything Cart consists of (2) Frames, (2) End Panels and (2) shelves with 6 bins. The End Panels consist of 20-gauge steel full height panels welded to 1" square 18-gauge steel tubing Frame with formed in handles that radius for added comfort and ease of movement. The Shelves are constructed of 20-gauge steel shelves that are 34" long x 17 3/16" deep on each side and a 6" high back. The shelves spot a 20" clearance between shelves and are welded to the frames and end panels of the Book Truck. All Book Trucks feature 4" diameter dual wheel casters with soft tread for quiet operation. Dual wheels have no saddle that may damage surrounding furniture.



**shown with optional booktruck riser shelf #21109.*

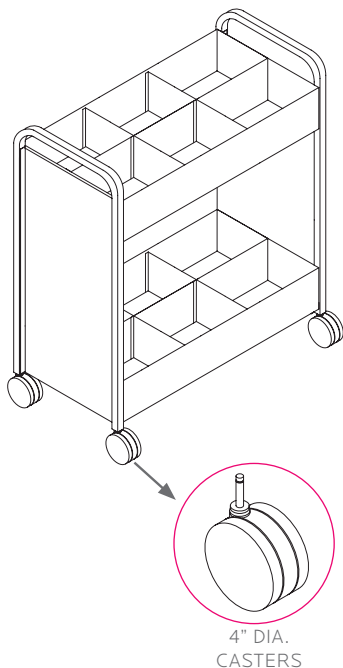
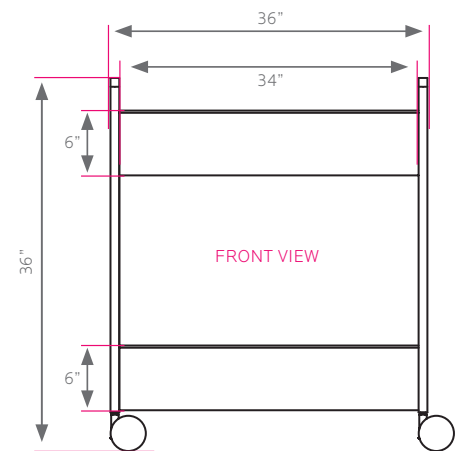
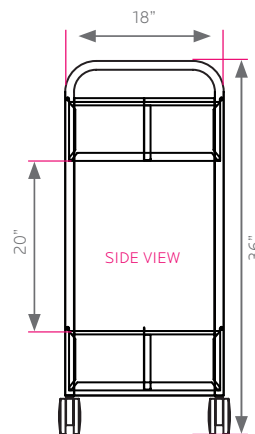
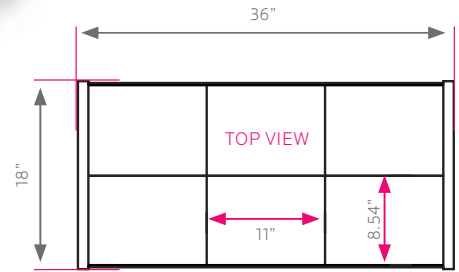

BOOKTRUCK COLOR CHOICE

- APPLE
- BLACK
- BLUEBERRY
- BURGUNDY
- CERULEAN
- CHAMPAGNE
- CHOCOLATE
- CLEMENTINE
- FOREST GREEN
- FUCHSIA
- MINT
- MOCHA
- NAVY
- PERSIAN BLUE
- PURPLE
- RED
- SAND
- YELLOW
- PLATINUM