

acrobat 'bullet' workstations

model #: 26512, 26515, 26516, 26522

acrobat 'bullet' workstations

DIMENSIONS + FREIGHT:

MODEL #	D"	W"	H"	F.C.	CUBE	WEIGHT
26512	30"	45"	24" - 36"	70	5.0	99 lbs.
carton	31.13"	51.3"	3.13"			
26515	24"	45"	24" - 36"	70	4.8	92 lbs.
carton	25.13"	51.3"	3.13"			
26516	30"	60"	24" - 36"	70	6.3	115 lbs.
carton	31.13"	63"	3.13"			
26522	30"	72"	24" - 36"	70	7.3	129 lbs.
carton	31.13"	75.3"	3.13"			

OVERVIEW:

The strong, stable Acrobat Workstations can be used separately or in multiple combinations. It features a built-in wire raceway in the modesty panel for cable management.

MATERIALS:

The 1 1/4" thick **WORK SURFACE** consists of a 45 lb. density particle board core with a .030" high-pressure laminated surface and a .020" melamine backer sheet. The edge of the work surface features 3/8" bumper edge molding that is mechanically fastened every 6 to 8 inches to assure a long lasting fit. The top is pre-drilled for ease of installation.

The **LEGS** are telescoping which allows height adjustment from 24" to 36" high. The legs are 1 5/8"W x 10"D double wall panel constructed of 12, 14 and 18-gauge steel with rounded edges. Cable ports in the upper leg create networking options from station to station and in the lower leg cable ports provide routing to the floor. The **BASE** is 16-gauge steel tube 1 3/4" x 2" nylon caps protect the feet. The legs also have 1" adjusting leveling glides.

The **MODESTY PANEL** is made from 18-gauge steel and features a built in raceway and cable ports in the upper corners. The panel connects to the worksurface and legs. Acrobat workstations can go mobile with optional 2.5" or 4" dual wheel casters.

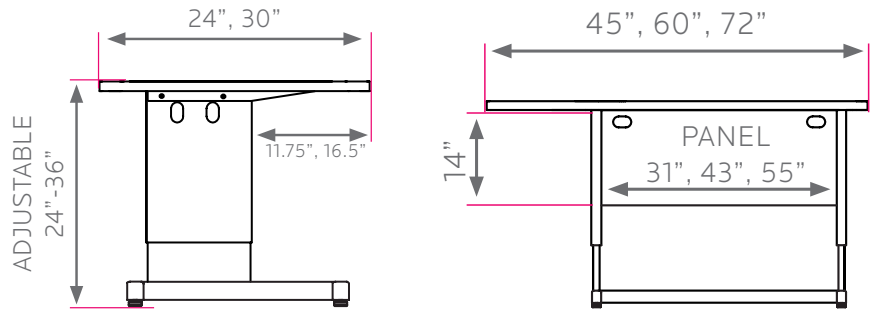

FRAME

- BLACK
- CHAMPAGNE
- PLATINUM

EDGE CHOICES

- | | | | |
|-------------|----------------|----------------|------------|
| ● APPLE | ● CHAMPAGNE | ● FUCHSIA | ● PURPLE |
| ● BLACK | ● CHARCOAL | ● MINT | ● RED |
| ● BLUEBERRY | ● CHOCOLATE | ● MOCHA | ○ WHITE |
| ● BURGUNDY | ● CLEMENTINE | ● NAVY | ● YELLOW |
| ● CERULEAN | ● FOREST GREEN | ● PERSIAN BLUE | ● PLATINUM |

LAMINATE CHOICES

- | | | |
|----------------|---------------|---------------|
| ● AMBER CHERRY | ● GOLDEN OAK | ● PEWTER MESH |
| ● ASIAN NIGHT | ● GREY MESH | ● TAN ECHO |
| ● BLOND ECHO | ● GREY NEBULA | ● WILD CHERRY |
| ● FUSION MAPLE | ● NEW AGE OAK | |

ACROBAT TOP & EDGE PROFILE

1 1/4" TOP

