

# graphic arts, CAD station

model #: 27344

two 24" x 24" surfaces, 1 slope adjustable

**DIMENSIONS + FREIGHT:**

MODEL #	D"	W"	H"	F.C.	CUBE	WEIGHT
27344	24"	48"	29"-39"	70	5.2	72 lbs.

**OVERVIEW:**

Planner Graphic Arts Tables bring their sturdy construction features to the art classroom. The 24" x 24" split-top model adds a flat work area for maximum workspace.

The work surface consists of a 7/8" thick high-pressure laminate bonded to a 3/4" thick 45-lb. density particle board core with a backer sheet and 3mm flat edges around the perimeter. The unit is constructed with a continuous hinge along the (width) front of the work surface, allowing up to 45 degrees of articulation of the work surface. The unit arrives with a curved easel attached to adjust the workstation to the desired position. The front & back channels come pre-assembled and are fully welded and constructed of 2" x 3" 14-gauge steel and provides lateral stability and a no sag work surface. The back channel has a 14-gauge plate welded inside the brace to support the 16-gauge curved easel. The legs are height adjustable for unit adjustment of 29" to 39" easily accommodating seating. Upper leg section is constructed of 1 1/4" square 14-gauge steel tubing. Lower leg inserts have tapped holes on 1" centers and attach to upper legs with 2 socket screws per leg. Legs are secured to the 3" x 1" 14-gauge leg brace by MIG weld. Each leg has a 1" adjusting leveling glide for stability.

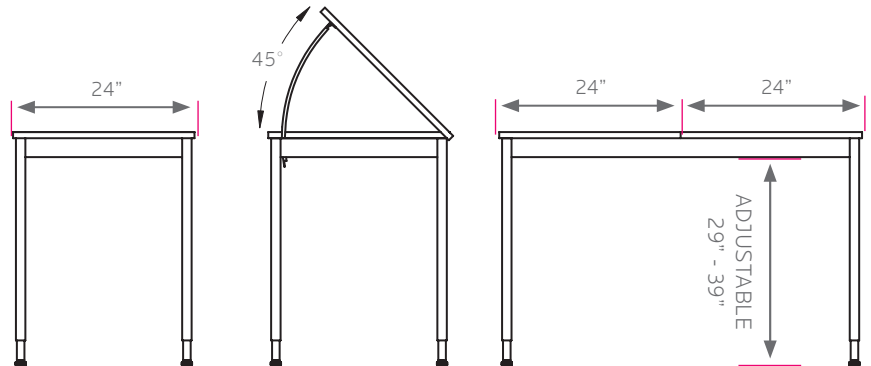

**OPTIONAL CPU HOLDER**

Model #17213



**OPTIONAL FLAT PANEL MOUNTS**



Model #17350



Model #17351

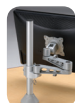

Model #17352



Model #17353



Model #17655

**graphic arts COLORS**

CHOICE 1	CHOICE 2	CHOICE 3
MAPLE	CHERRY	GREY
MAPLE	BLACK	BLACK
BLACK	BLACK	BLACK



PAIR WITH OUR STOOL SELECTIONS

\*see catalog for all optional parts & accessories.