

cascade mega-case av cart

model #: V21100000P_

mega-case AV cart w/ riser shelf

DIMENSIONS + FREIGHT:

MODEL #	D"	W"	H"	F.C.	CUBE	WEIGHT
V21100000P	19"	43"	37"	100	22.7	131 lbs.
pallet dims	26"	45"	32"			

OVERVIEW:

The Cascade mega-case AV Presentation Cart provides movable, lockable storage for AV equipment and a durable work surface. Includes 4 Power Outlets outside, 5 Power Outlets inside as well as 4 wire holes and a perforated rear vent panel.

The **END PANELS** are made of 18-gauge 1" square tubing, welded flush to an 18-gauge end panel. The inside of each end panel is reinforced by 22-gauge hat channels. These hat channels are dual purpose: added strength and for tote rail shelf mounting. The dome top is 18-gauge formed and welded construction, bolted to each end panel and rear panel. The base is a durable 18-gauge steel construction formed and welded to support the entire weight of the unit squarely. Underneath is a heavy welded hat channel reinforcement. The base shelf is attached to both end panels. The Rear Panel is 18-gauge steel reinforced. Two grommet holes (a lower and upper) are punched for convenient wire management and electronic storage. Casters are 5" in diameter, with 2 locking. Optional glides are 3/8" threaded stem.

RISER SHELVES are sized perfectly for each cabinet size. These riser shelves are made of 1 1/4" high density particle board with your choice of laminate and T-Mold color. Shelf is suspended 6 inches above the dome top with 4 riser shelf handles, which measure 1 1/2" diameter and come in Platinum powder coat paint finish (0.03" Thickness). These riser shelf handles bolt on from underneath the dome top with a hefty 3" washer.

The **DOORS** include a secure and reliable locking mechanism, which engages lock rods into the dome top and the base shelf. Doors also come with urethane ergonomic and modern door handles of your color choice. The fully hinged doors articulate 270 degrees, free of obstruction.

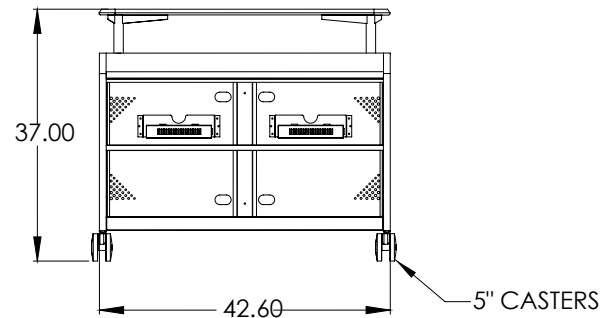
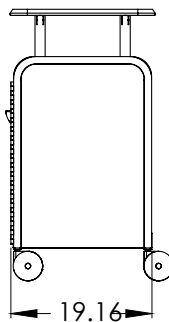

SHELVES & FRAME

- PLATINUM **PLT**

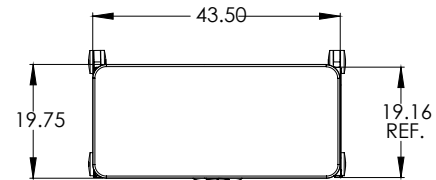

END PANEL & EDGE MOLDING COLORS

- | | | | |
|----------------------|-------------------------|-------------------------|---------------------|
| ● APPLE A | ● CHARCOAL R | ● MINT H | ● RED L |
| ● BLACK B | ● CHOCOLATE Q | ● MOCHA T | ○ WHITE M |
| ● BLUEBERRY C | ● CLEMENTINE E | ● NAVY I | ● YELLOW N |
| ● BURGUNDY D | ● FOREST GREEN F | ● PERSIAN BLUE J | ● PLATINUM P |
| ● CERULEAN S | ● FUCHSIA G | ● PURPLE K | |
| ● ORANGE U | | | |

LAMINATE CHOICES

- | | | |
|---------------------------|--------------------------|--------------------------|
| ● AMBER CHERRY AME | ● GOLDEN OAK GOK | ● PEWTER MESH PEW |
| ● ASIAN NIGHT ANG | ● GREY MESH GRE | ● TAN ECHO TAC |
| ● BLOND ECHO BEE | ● GREY NEBULA GNB | ● WILD CHERRY CHE |
| ● FUSION MAPLE MAP | ● NEW AGE OAK NEW | |

- 1 1/4" Tops**
- N = (1 1/4" Bumper T-Mold)
 - Q = (1 1/4" 4mm T-mold)

Mid-Case AV with riser available with 1 1/4" top only.

Choice **N** is standard edge. For optional edge option **Q**, replace **N** with **Q** in model number.

*see catalog for all optional parts & accessories.