

# cascade mega-tower cubby

model #: F11000000P\_

## mega-tower cubby

### DIMENSIONS + FREIGHT:

MODEL #		D"	W"	H"	F.C.	WEIGHT
F11000000P_	open, 12 cubby	19"	43"	61.4"	100	135 lbs.
F21000000P_	doors, 12 cubby	19"	43"	61.4"	100	154 lbs.

### OVERVIEW:

Featuring twelve compartments and a selection of nineteen beautiful finish colors, the Cascade Cubby offers an open-shelf layout with easy access for maximizing storage in any classroom setting. The powder coated all steel construction maximizes durability guarantying many years of service.

### MATERIALS:

The **END PANELS** are made of 18-gauge 1" square tubing, welding flush to an 18-gauge end panel. The inside of each end panel is reinforced by 22-gauge hat channels. These hat channels are dual-purpose: added strength and for tote rail shelf mounting. The dome top is 18-gauge formed and welded construction, bolted to each end panel and rear panel with a total of ten machine screw fasteners. The base is a durable 18-gauge steel construction formed and welded to support the entire weight of the unit squarely. Underneath is a heavy welded hat channel for reinforcement. The base shelf is attached to both end panels using four machine screw fasteners. The rear panel is 18-gauge steel reinforced with up to three vertical hat channels. Two grommet holes (a lower and an upper) are punched for convenient wire management and electronic storage. The 18-gauge cubby dividers bolt to the 16-gauge center supports that are bolted to the dome supports and hat channels. Casters are 5" in diameter, with two locking. Optional glides are 3/8" threaded stem.

The **OPTIONAL DOORS** include a secure and reliable locking mechanism, which engages lock rods into the dome top and the base shelf. Doors also come with urethane ergonomic and modern door handles of your color choice. The fully hinged doors articulate 270°, free of obstruction.

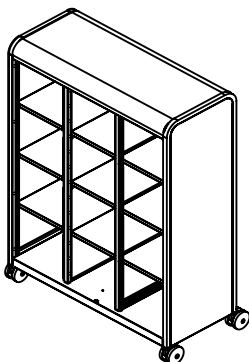

\*see catalog for all optional parts & accessories.

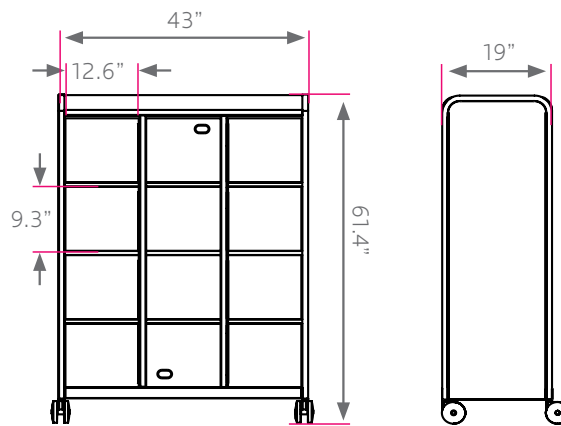

### SHELVES & FRAME

● PLATINUM **PLT**

### END PANEL & EDGE MOLDING COLORS\_

- |                      |                         |                         |                     |
|----------------------|-------------------------|-------------------------|---------------------|
| ● APPLE <b>A</b>     | ● CHARCOAL <b>R</b>     | ● MINT <b>H</b>         | ● RED <b>L</b>      |
| ● BLACK <b>B</b>     | ● CHOCOLATE <b>Q</b>    | ● MOCHA <b>T</b>        | ○ WHITE <b>M</b>    |
| ● BLUEBERRY <b>C</b> | ● CLEMENTINE <b>E</b>   | ● NAVY <b>I</b>         | ● YELLOW <b>N</b>   |
| ● BURGUNDY <b>D</b>  | ● FOREST GREEN <b>F</b> | ● PERSIAN BLUE <b>J</b> | ● PLATINUM <b>P</b> |
| ● CERULEAN <b>S</b>  | ● FUCHSIA <b>G</b>      | ● PURPLE <b>K</b>       |                     |