

cascade mid-tower

model #: 811000000P_

mid-tower w/ shelves

DIMENSIONS + FREIGHT:

| MODEL # | | D" | W" | H" | F.C. | WEIGHT |
|-------------|-----------------|-----|-----|-------|------|----------|
| 811000000P_ | open w/ shelves | 19" | 29" | 61.4" | 100 | 125 lbs. |
| 821000000P_ | door w/ shelves | 19" | 29" | 61.4" | 100 | 151 lbs. |

OVERVIEW:

The Cascade series provides storage for a wide variety of items. The Mid-Tower is a medium width, high height cabinet in the Cascade grouping, measuring in at 61 3/8" tall, 28 5/8" wide and 19" deep.

MATERIALS:

The **END PANELS** are made of 18-gauge 1" square tubing, welded flush to an 18-gauge end panel. The inside of each end panel is reinforced by 22-gauge hat channels. These hat channels are dual purpose: added strength and for tote rail shelf mounting. The dome top is 18-gauge formed and welded construction, bolted to each end panel and rear panel with a total of 10 machine screw fasteners. The base is a durable 18-gauge steel construction formed and welded to support the entire weight of the unit squarely. Underneath is a heavy welded hat channel reinforcement. The base shelf is attached to both end panels using 4 machine screw fasteners. The Rear Panel is 18-gauge steel reinforced with up to three vertical hat channels. Two grommet holes (a lower and upper) are punched for convenient wire management and electronic storage. Casters are 4" in diameter, with 2 locking. Optional glides are 3/8" threaded stem.

The **optional DOORS** include a secure and reliable locking mechanism, which engages lock rods into the dome top and the base shelf. Doors also come with urethane ergonomic and modern door handles of your color choice. The fully hinged doors articulate 270 degrees, free of obstruction.

Due to the Cascade Tower's height, **riser shelves are not available on Cascade Mini Tower, Mid Tower or Mega Tower.**

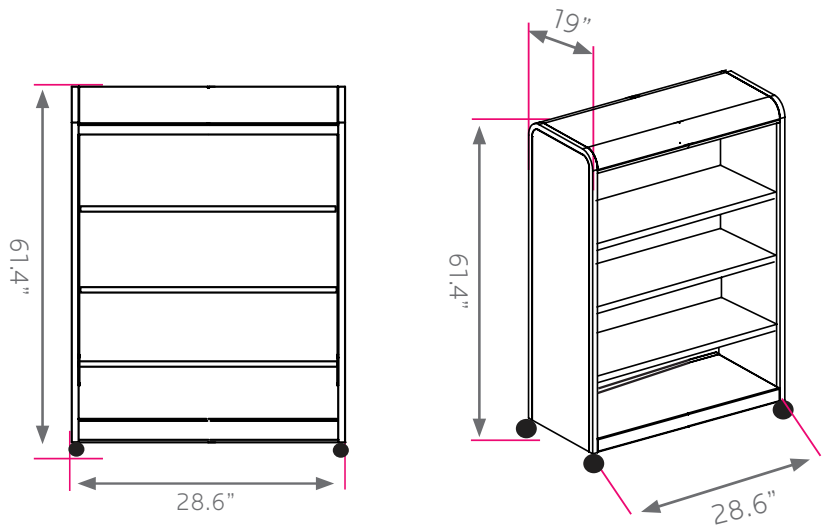

SHELVES & FRAME

● PLATINUM **PLT**

END PANEL & EDGE MOLDING COLORS

- | | | | |
|----------------------|-------------------------|-------------------------|---------------------|
| ● APPLE A | ● CHARCOAL R | ● MINT H | ● RED L |
| ● BLACK B | ● CHOCOLATE Q | ● MOCHA T | ○ WHITE M |
| ● BLUEBERRY C | ● CLEMENTINE E | ● NAVY I | ● YELLOW N |
| ● BURGUNDY D | ● FOREST GREEN F | ● PERSIAN BLUE J | ● PLATINUM P |
| ● CERULEAN S | ● FUCHSIA G | ● PURPLE K | |

*see catalog for all optional parts & accessories.