

dual surface, clamp on lectern

model #: 00470

dual surface lectern, with clamp-on attachment

DIMENSIONS & FREIGHT:

MODEL #	D"	W"	H"	F.C.	WEIGHT
00470	19"	19"	6"	70	22 lbs.

OVERVIEW:

The Dual Surface Model #00470, can be attached to any of our tops using the easy clamp on system. The Lectern is easily adjusted in height and is fully versatile in it's range of motion - a full 360° of motion with the fully actuating arm. The Dual Surface's of the lectern allow for easy access to any (2) items at once, i.e. a laptop computer on the lower shelf and a notebook on the upper shelf (as pictured) or any number of other combinations. The Dual Surface lectern has 16-gauge steel construction along with a reinforcement brace. Another key feature is the integrated pencil retainer.

COMPATIBILITY:

Compatible with booktruck & cascade riser shelf tops and a wide variety of Smith System desks and tables.

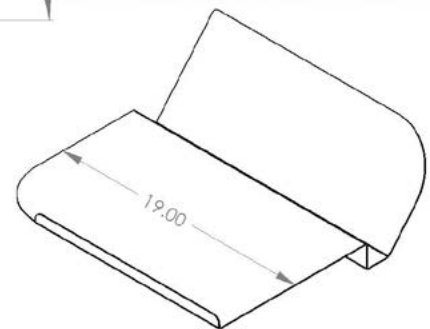
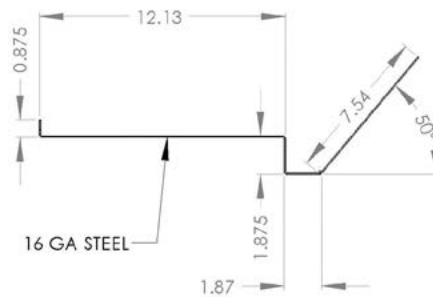
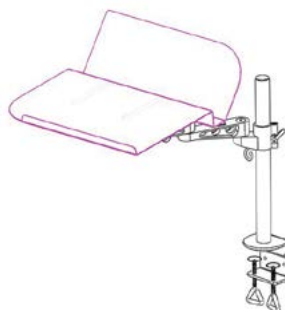
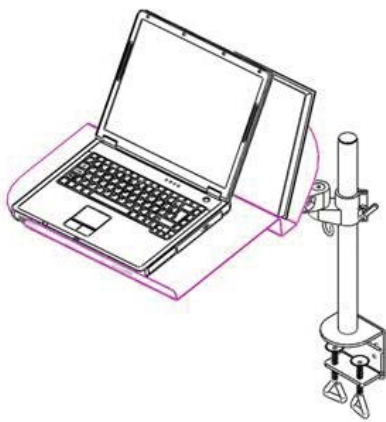

DUAL SURFACE LECTERN COLOR CHOICE

- APPLE
- CHAMPAGNE
- MINT
- RED
- BLACK
- CHOCOLATE
- MOCHA
- YELLOW
- BLUEBERRY
- CLEMENTINE
- NAVY
- PLATINUM
- BURGUNDY
- FOREST GREEN
- PERSIAN BLUE
- CERULEAN
- FUCHSIA
- PURPLE