

planner activity tables 36" deep

model #: 25550-25580

planner activity tables 36" deep
x 48", 60", 72" and 90" length.

DIMENSIONS + FREIGHT:

MODEL #	D"	W"	H"	F.C.	CUBE	WEIGHT
25550	36"	48"	24" - 34"	70	3.6	102 lbs.
25560	36"	60"	24" - 34"	70	4.5	118 lbs.
25570	36"	72"	24" - 34"	70	5.4	135 lbs.
25580	36"	90"	24" - 34"	70	6.8	158 lbs.

OVERVIEW:

The Planner is ideal for all kinds of classroom activities. The heavy duty construction contributes to a sturdy work surface that can hold 400 pounds. The Planner Activity table is shipped ready to assemble.

The 1 1/4" or 3/4" thick **WORK SURFACE** consists of a 45 lb density particle board core with a .030" high pressure laminated surface and a .020" melamine backer sheet. The edge of the work surface features t-mold edge molding that is fastened every 6 to 8 inches to assure a long lasting fit.

The **FRAME** consists of two fully welded leg segments and a center support channel. The legs are attached to the pre-drilled holes in the top with (16) #10 x 5/8" wood screws through a 3 1/8" w x 18"L 12-gauge steel mounting plate. The mounting plate is welded to (2) 1 1/4" square 12-gauge steel tube legs which is welded to a 1" x 2" 14-gauge steel tube cross bar. The leg inserts are 1" square 14-gauge steel tube and adjust in height from 24" to 34" in 1" increments. Leveling glides are on each table leg allowing for stability on uneven floors. The adjustment for each leg is secured with (2) 3 3/4" -16 x .675" Allen screws. The center support channel is 2" x 3" 14-gauge steel, with 11-gauge steel end plates for maximum stability. The center support channel is connected to the legs by (4) connector bolts.

PLANNER DESK TOP & EDGE PROFILE

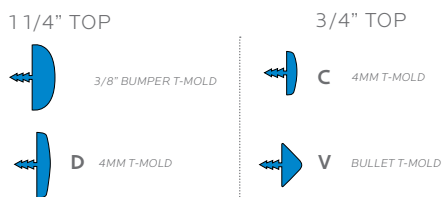

*see catalog for all optional parts & accessories.

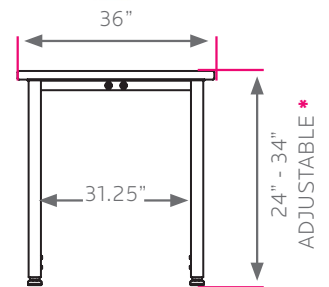
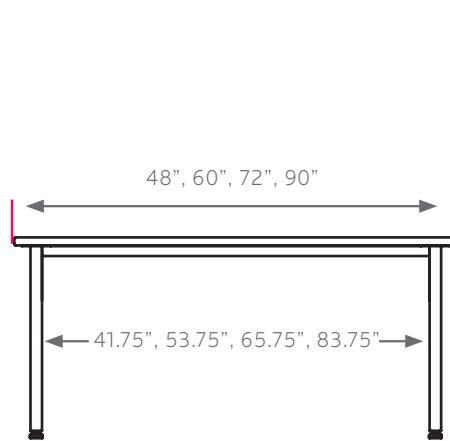

- * Low range available in 15-24"h. Add **L** following model number.
- Fixed-height leg available in 29.5"h. Add **X** following model number. Available in Black only.

- Center support channel is 2" by 3" wide 14-gauge steel, with 11-gauge steel endplates for maximum stability.

FRAME

- BLACK
- PLATINUM



EDGE CHOICES

- APPLE
- BLACK
- BLUEBERRY
- BURGUNDY
- CERULEAN
- ORANGE
- CHAMPAGNE
- CHARCOAL
- CHOCOLATE
- CLEMENTINE
- FOREST GREEN
- FUCHSIA
- MINT
- MOCHA
- NAVY
- PERSIAN BLUE
- PURPLE
- RED
- WHITE
- YELLOW
- PLATINUM

LAMINATE CHOICES

- AMBER CHERRY
- ASIAN NIGHT
- BLOND ECHO
- FUSION MAPLE
- GOLDEN OAK
- GREY MESH
- GREY NEBULA
- NEW AGE OAK
- PEWTER MESH
- TAN ECHO
- WILD CHERRY