

planner lab station 30" x 30"

model #: 24530

one-student planner lab 30" x 30"

DIMENSIONS + FREIGHT:

MODEL #	D"	W"	H"	F.C.	CUBE	WEIGHT
24530	30"	30"	22" - 32"	70	2.0	59 lbs.
carton	30.1"	32.5"	3"			

OVERVIEW:

The Planner is a truly stronger student desk. Shipped ready to assemble, these desks have a heavy-duty work surface that won't sag under heavy books or equipment.

The 1 1/4" thick **WORK SURFACE** consists of a 45 lb density particle board core with a .030" high pressure laminated surface and a .020" melamine backer sheet. The edge of the work surface features 3/8" bumper edge molding that is fastened every 6 to 8 inches to assure a long lasting fit. The top has one or two arch shaped cutouts in the rear and is pre-drilled for ease of installation.

The **FRAME** is attached to the pre-drilled holes in the top with (12) #10 x 5/8" screws through a 3 1/8" W x 18" L 14-gauge steel mounting plate. The mounting plate is welded to (2) 1 1/4" square 14-gauge steel tube legs which are welded to a 1" square 14-gauge steel tube cross bar. The leg inserts are 1" square 14-gauge steel tube and adjust in height from 22" to 32" in 1" increments. The adjustment for each leg is secured with (2) 3 3/4"-16 x .675" Allen screws. The right and left leg both include the Smith System patented backpack peg allowing for either inside or outside positioning. Legs have 1" adjusting leveling glides.

WIRE MANAGEMENT includes a 3"d x 6"h wire tray mounted to the underside of the work surface with #10 x 3/4" screws. The tray also mounts to each leg using a total of 4 Connector bolts. Wire trays for tables under 60" wide have one grommet hole for wire management, 60" and wider have two grommet holes.

PLANNER LAB TOP & EDGE PROFILE

1 1/4" TOP

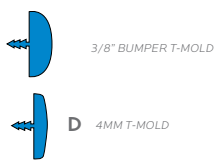

3/8" BUMPER T-MOLD

D 4MM T-MOLD



Make it mobile with 3" casters
Order Model 17576

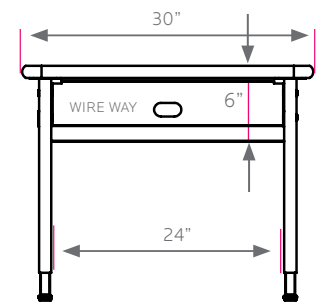
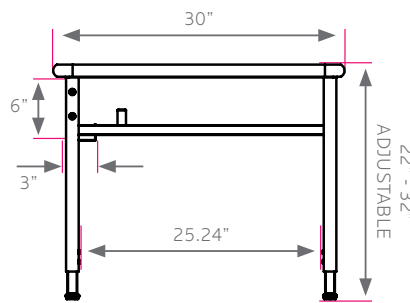
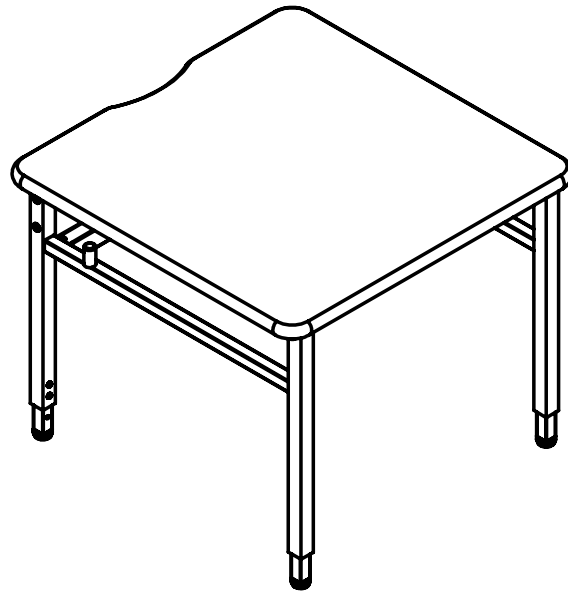

FRAME

- BLACK
- PLATINUM

EDGE CHOICES

- APPLE
- BLACK
- BLUEBERRY
- BURGUNDY
- CERULEAN
- ORANGE
- CHAMPAGNE
- CHARCOAL
- CHOCOLATE
- CLEMENTINE
- FOREST GREEN
- FUCHSIA
- MINT
- MOCHA
- NAVY
- PERSIAN BLUE
- PURPLE
- RED
- WHITE
- YELLOW
- PLATINUM

LAMINATE CHOICES

- AMBER CHERRY
- ASIAN NIGHT
- BLOND ECHO
- FUSION MAPLE
- GOLDEN OAK
- GREY MESH
- GREY NEBULA
- NEW AGE OAK
- PEWTER MESH
- TAN ECHO
- WILD CHERRY

*see catalog for all optional parts & accessories.