

# library carrels

model #: 26680-26685

library carrels, starter & adder

**DIMENSIONS + FREIGHT:**

MODEL #	'D' & 'E'	'C'	'A'	'B'	F.C.	WEIGHT
<b>carrel starters</b>						
26680	27.625"	24"	48"	21.5"	70	128 lbs.
26682	27.625"	36"	48"	33.5"	70	145 lbs.
26684	27.625"	48"	48"	45.5"	70	163 lbs.
<b>carrel adders</b>						
26683	27.625"	36"	48"	33.5"	70	104 lbs.
26685	27.625"	48"	48"	45.5"	70	119 lbs.
26681	27.625"	24"	48"	21.5"	70	87 lbs.

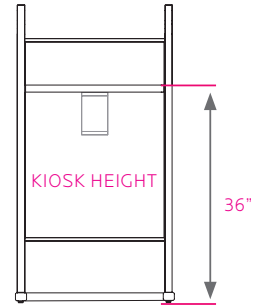

**OVERVIEW:**

Focusing on studying can be a challenge for children of all ages. Library carrels can be a great solution to this problem and are perfect for libraries. By just reversing the back panel you can switch from desk height to kiosk height.

**MATERIALS:**

The 1 1/4" thick work surface consists of 45 lb. density particle board core with a .030" high-pressure laminated surface and a .020" melamine backer sheet. The work surface is finished on the edge with a t-mold edge of your choice that is mechanically fastened every 6 to 8 inches to assure a long lasting fit. The top is pre-drilled for ease of installation. The 1 1/4" thick side panels consist of the same 45 lb. density particle board core, .030" high-pressure laminate on both sides and the edge is wrapped with t-mold. The side panels are finished with a 16-gauge 1 3/4" x 2" steel foot with nylon end caps and feature 1" adjustable leveling glides that provide stability on uneven floors. The back panel is an 18-gauge steel panel and is reversible to allow the user to set their work surface at either a 28" desk height for sitting or a 36" kiosk height for standing. For added strength the side panels are tied together with a 14-gauge steel tube cross bar at the foot.

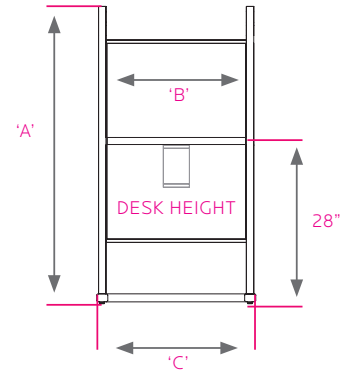
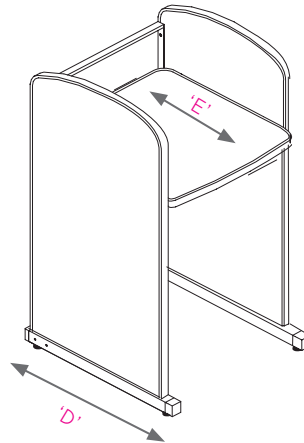

**Acrobat Carrel Top and Edge Choices**



**CHOICE 1** - 1 1/4" top with Bumper T-Mold no letter to follow Model No.



**CHOICE 2** - 1 1/4" top with 4mm T-Mold to follow Model No.

**ACROBAT CARREL LAMINATE COLOR CHOICE**

- Amber Cherry
- Blond Echo
- Golden Oak
- Grey Nebula
- Pewter Mesh
- Wild Cherry
- Asian Night
- Fusion Maple
- Grey Mesh
- New Age Oak
- Tan Echo

**FRAME COLOR CHOICE**

- Black
- Platinum

**ACROBAT CARREL EDGE COLOR CHOICE**

- Apple
- Burgundy
- Charcoal
- Forest Green
- Mocha
- Persian Blue
- Red
- Black
- Cerulean
- Chocolate
- Fuchsia
- Navy
- Platinum
- White
- Blueberry
- Champagne
- Clementine
- Mint
- Orange
- Purple
- Yellow