

silhouette sequence

adjustable height w/ glide

model #: 01655

DIMENSIONS + FREIGHT:

MODEL #	D"	W"	H"	F.C.	CUBE	WEIGHT
01655	23"	31"	19"-31"	70	1.2	36 lbs.
carton	24"	34"	7"			

OVERVIEW:

Shipped ready to assemble, these desks have a heavy-duty work surface that won't sag under heavy books or equipment. The Silhouette Sequence Desk is great for rows, pairs, or collaborative pods for learning in groups.

The **WORK SURFACE** consists of a 45 lb density particle board core with a .030" high pressure laminated surface and a .020" melamine backer sheet. The edge of the work surface features 3/8" bumper edge molding that is fastened every 6 to 8 inches to assure a long lasting fit. The frame is attached to the pre-drilled holes in the top with (6) #10 screws through a 1" x 1.75" 18-gauge steel channel. The mounting channel is welded to a 1" x 2" rectangular 16-gauge steel tube leg. The leg inserts are 1" x 1.75" 16-gauge steel tube and are **adjustable in height** from 19" to 31". Model 01655 comes standard with a lockable endcap/**glide** combination. The legs are tied together for added strength with a 1" x 2" 16-gauge steel tube stretcher bar and (4) bolts.

SILHOUETTE TOP & EDGE PROFILE

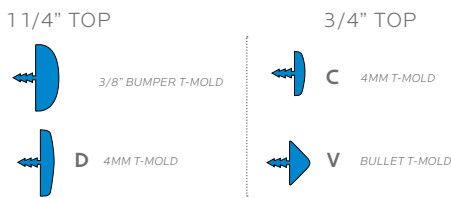

OPTIONAL ACCESSORIES

MODEL #		D"	W"	H"	F.C.	CUBE	WEIGHT
17190	steel bookbox	15"	20"	4"	70	3.0	8 lbs.
17200	wire book-basket	15"	18"	3.5"	70	3.0	5 lbs.
30925	SW tray w/ housing	16.8"	13.5"	3"	70	1.2	8 lbs.
30926	EW tray w/ housing	16.8"	19.6"	3"	70	1.2	10 lbs.

Make it mobile with casters
Order Model 17576



Model 01655.
Shown with optional SW tote tray w/ housing Model 30925.

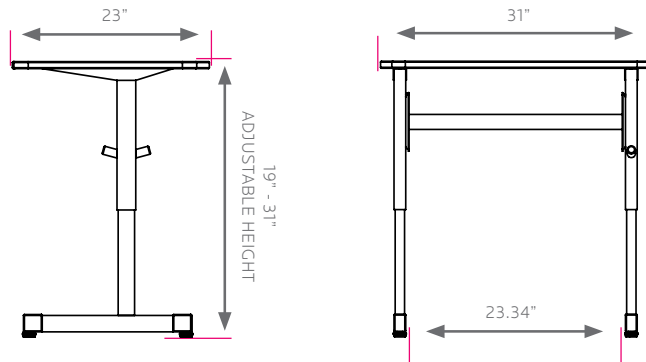
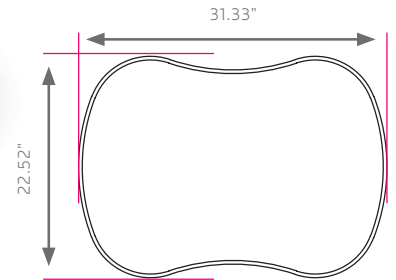

FRAME

- BLACK
- PLATINUM

EDGE CHOICES

- APPLE
- CHAMPAGNE
- FUCHSIA
- PURPLE
- BLACK
- CHARCOAL
- MINT
- RED
- BLUEBERRY
- CHOCOLATE
- MOCHA
- WHITE
- BURGUNDY
- CLEMENTINE
- NAVY
- YELLOW
- CERULEAN
- FOREST GREEN
- PERSIAN BLUE
- PLATINUM
- ORANGE

LAMINATE CHOICES

- AMBER CHERRY
- GOLDEN OAK
- PEWTER MESH
- ASIAN NIGHT
- GREY MESH
- TAN ECHO
- BLOND ECHO
- GREY NEBULA
- WILD CHERRY
- FUSION MAPLE
- NEW AGE OAK