

INTERCHANGE CRESCENT

ASSEMBLY INSTRUCTIONS

Special Notes:

1. Check that all components are accounted for and undamaged before assembling.
2. Please assemble product in a clean, dry area.
3. For larger units, you may need assistance from another individual to assemble the unit.
4. Clean the product with a mild cleaner and a damp cloth.



smithsystem.com | 1 800 328 1061

INTERCHANGE CRESCENT

Crescent 60" # 04157
 Crescent 72" # 04156

HARDWARE PACK #67607 (INTERCHANGE ACTIVITY)			
	Part Number	Description	Quantity
A	#77813	3/16" Allen Wrench	(2)
B	#70867	Connector Bolt 1/4 - 20 x 23mm	(4)
C	#70869	Connector Nut 1/4 - 20 x 17mm	(4)
D	#70054	#10 x 3/4" Wood Screws	(26)



A x2

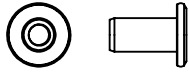

C x4

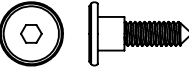

B x4



D x26

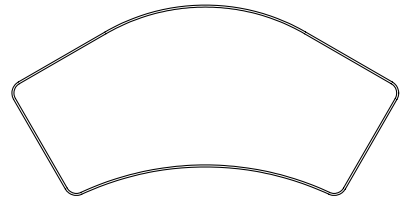

INTERCHANGE CRESCENT TABLETOP

Part Number	Description	Quantity
#04156	72" Crescent Top	(1)
OR		
#04157	60" Crescent Top	(1)

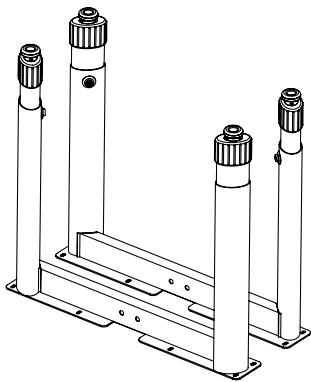

INTERCHANGE CRESCENT LEG SET

Part Number	Description	Quantity
#79804	72" Crescent Leg Set	(1)
OR		
#79803	60" Crescent Leg Set	(1)



smithsystem.com | 1 800 328 1061

INTERCHANGE CRESCENT

Crescent 60" # 04157
 Crescent 72" # 04156

INTERCHANGE 5TH LEG SET #79528 (04156)/ 79529 (04157)

Item #	Part Number	Description	Quantity
1	#P12925	Interch. Crescent SLEG BRKT.	(1)
2	#P10506	Ellipse Leg, Single, Ellipse	(1)
3	70201	Nyloc Bolt - 1/4 - 20 Thread	(2)
4	#1.4-20 x 500_SCREW	1/-20 x .500 PAN HEAD Phillips w/ Nylon Patch	(2)
5	#P12923	T-NUT BRKT - Crescent Single Leg	(1)
6	#70054	#10 x 3/4" Hi Lo Path Screw	(6)
7	#77536 or 77508 (04156) (04157)	51.76" or 41.75" Support Channel	(1)
8	#77513	Support Channel Brackets (Pair)	(1)

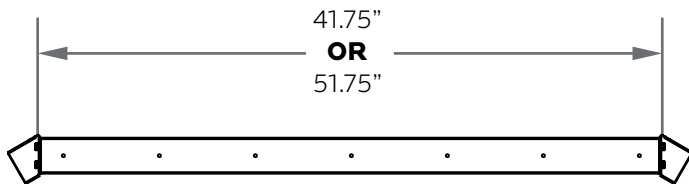
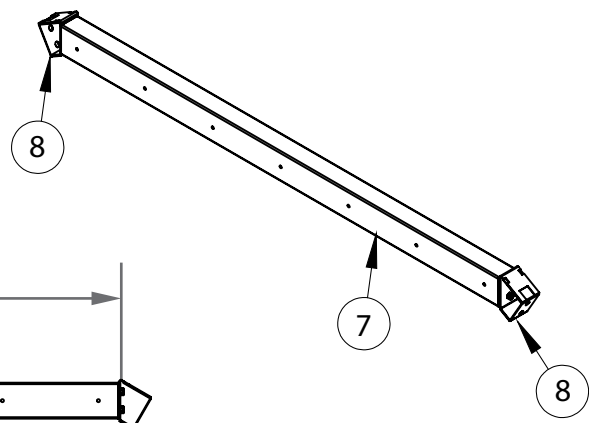
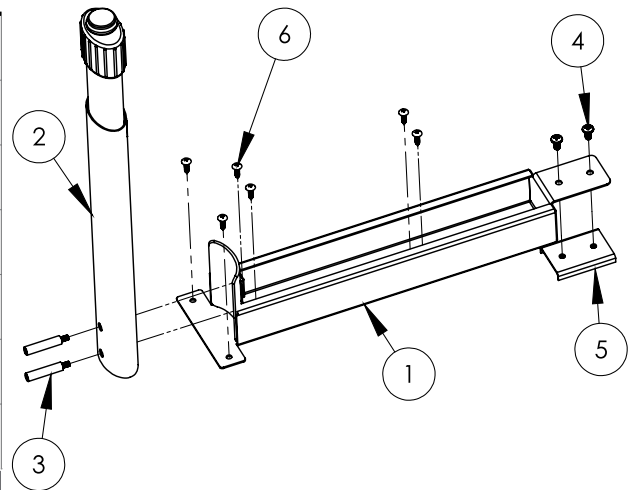

smithsystem.com | 1 800 328 1061

July 2017

Form #179991

INTERCHANGE CRESCENT

Crescent 60" # 04157
Crescent 72" # 04156

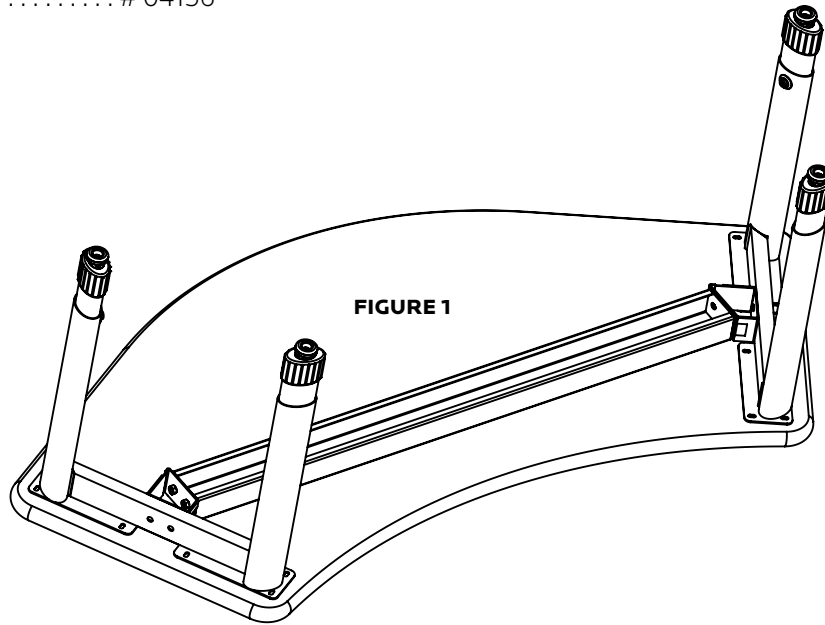

STEP 1: Place the top on a clean, dry surface laminate side down, so that the predrill holes face up.

STEP 2: Loosely attach the channel brackets (#77513) and support channel (#77536/77508) assembly using the (4) connector nuts from hardware pack that came with the leg set.

See figure 1A

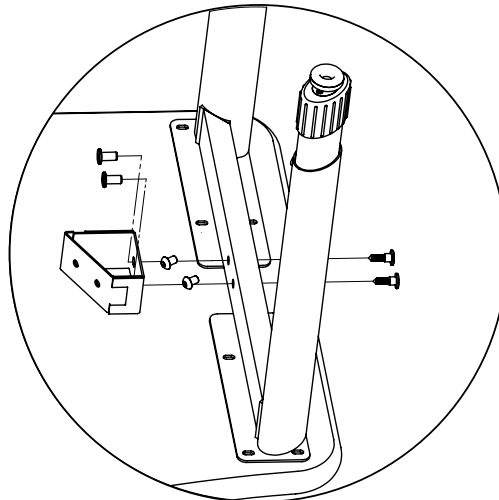

FIGURE 1A



smithsystem.com | 1 800 328 1061

INTERCHANGE CRESCENT

Crescent 60" # 04157

Crescent 72" # 04156

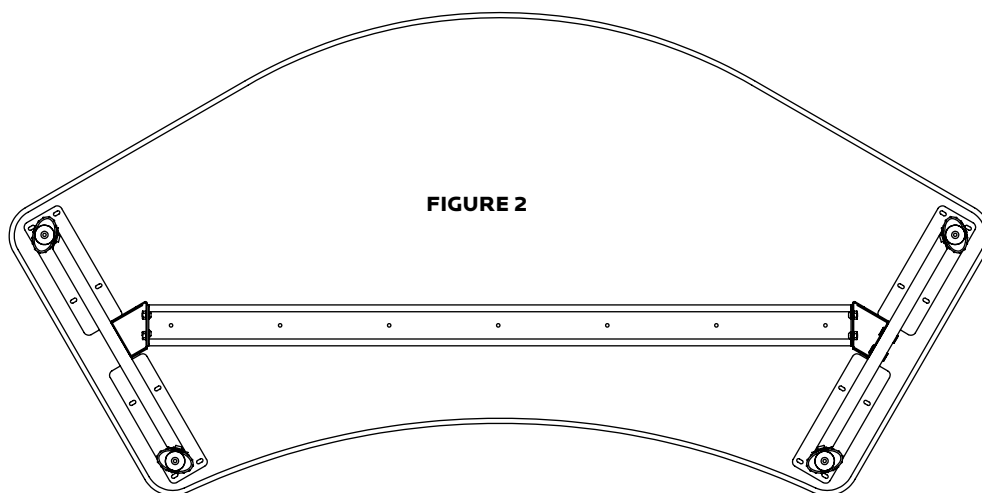

tip stagger screws during assembly; i.e. fasten one screw into one of the legs, then another screw on the other leg. Continue to stagger until all screws are used.

STEP 3: Align the slots of the leg assemblies to the pre-drilled holes of the top - using the 3/4" wood screws that came with the leg set, attach the leg assembly to the top.

STEP 4: Tighten the connector bolts and nuts to the leg sets using the two Allen Keys provided.



smithsystem.com | 1 800 328 1061

INTERCHANGE CRESCENT

Crescent 60" # 04157

Crescent 72" # 04156

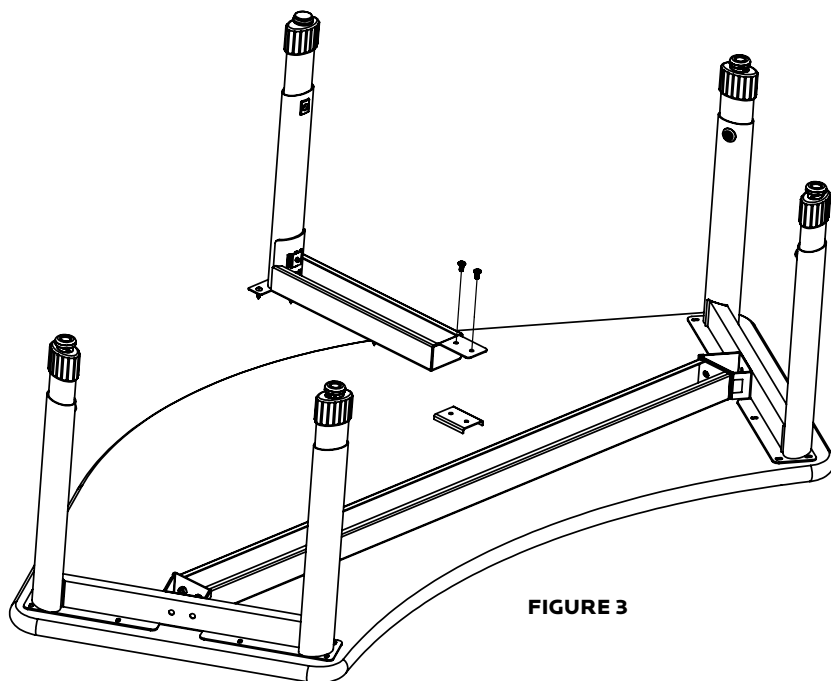

STEP 5: Rotate the T-Nut bracket 90° and insert into channel support. Loosely attach 1 / 4-20 screws through the single leg bracket (#26663). Maneuver single leg bracket until screw holes align with predrilled holes in the top - Install Screws.



smithsystem.com | 1 800 328 1061

July 2017

Form #179991

INTERCHANGE CRESCENT

Crescent 60" # 04157
Crescent 72" # 04156

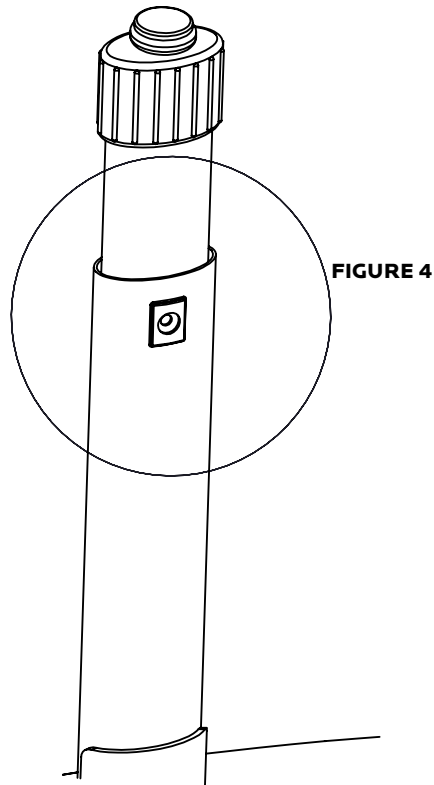

STEP 6: Adjust the leg height as desired by loosening the set screw in each leg (using the Allen Key provided). Move leg to desired height - and be sure to locate the appropriate hole in the leg.

**DO NOT USE A POWER TOOL FOR LEG ADJUSTMENT!
HAND TIGHTEN WITH ALLEN KEY ONLY!**

STEP 7: Use the help of at least one other individual to turn the table over and into it's upright position.



smithsystem.com | 1 800 328 1061