

# acrobat 'bullet' workstation

model #: 26538

acrobat 'bullet' workstation 30x72 with Model #04619 Lectern + Model #19173 Drawer Pedestal included.

**DIMENSIONS + FREIGHT:**

MODEL #	D"	W"	H"	F.C.	CUBE	WEIGHT
26538	30"	72"	24" - 36"	70	15	215 lbs.
carton	31.13"	75"	3.13"			

**OVERVIEW:**

The strong, stable Acrobat Workstations can be used separately or in multiple combinations. It features a built-in wire raceway in the modesty panel for cable management.

The 1 1/4" thick **WORK SURFACE** consists of a 45 lb. density particle board core with a .030" high-pressure laminated surface and a .020" melamine backer sheet. The edge of the work surface features 3/8" bumper edge molding that is mechanically fastened every 6 to 8 inches to assure a long lasting fit. The top is pre-drilled for ease of installation.

The **LEGS** are telescoping which allows height adjustment from 24" to 36" high. The legs are 1 5/8"W x 10"D double wall panel constructed of 12, 14 and 18-gauge steel with rounded edges. Cable ports in the upper leg create networking options from station to station and in the lower leg cable ports provide routing to the floor. The **BASE** is 16-gauge steel tube 1 3/4" x 2" nylon caps protect the feet. The legs also have 1" adjusting leveling glides.

The **MODESTY PANEL** is made from 18-gauge steel and features a built in raceway and cable ports in the upper corners. The panel connects to the worksurface and legs. Acrobat workstations can go mobile with optional dual-wheel casters:

- Model #17576 = 3" diameter
- Model #17554 = 4" diameter

**INCLUDED w/ Model #26538:**  
 #19173 Drawer Pedestal  
 #04619 Desktop Lectern

**ACROBAT TOP & EDGE PROFILE**

1 1/4" TOP

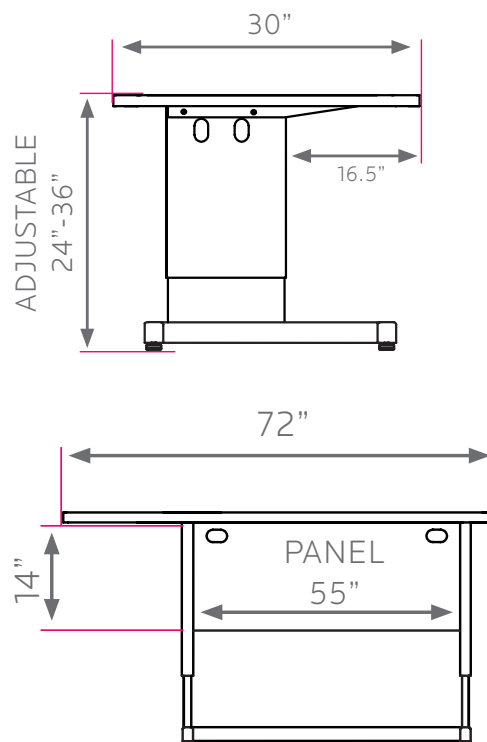

# deluxe tabletop lectern

model #: 04619

tabletop lectern



## DIMENSIONS:

MODEL #	D"	W"	H"	F.C.	WEIGHT
04619	20"	18"	13"	125	21 lbs.
carton	22.5"	20.5"	16"		

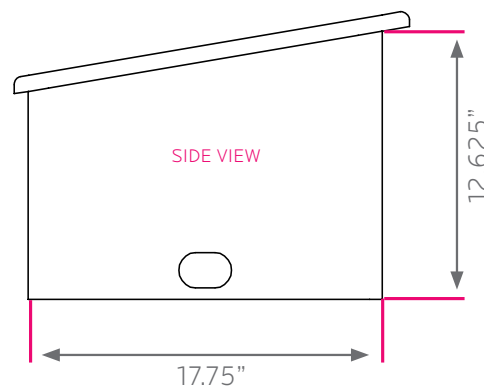
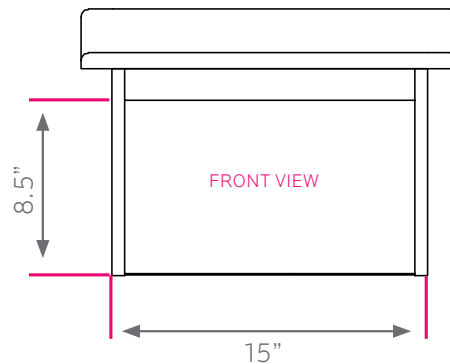

## OVERVIEW:

This convenient tabletop model can make a strong statement in classrooms, libraries, meeting rooms and more. Choose from 13 laminates choices, 20 edge molding colors and Black or Platinum frame.

The 3/4" thick work surface has a retaining lip to aid items from falling off. The tabletop lectern is made out of durable metal, yet light weight for easy movement. With it weighing less than 20 pounds, it is easily mobile and can be transported with ease. The spacious storage area is constructed of 19-gauge steel that is 17.75"d x 15"w. The storage area also has 3 grommet holes for wire management.

## top & edge PROFILE



3/4" TOP

## Frame Color Options



BLACK



PLATINUM

## Standard Laminate Options

### Want to specify a different laminate?

No problem. If you have 20 or more tops of the same color -60 or -38 there is no upcharge. Have 20 or less? We can quote for you with the Wilsonart code and – finish style. We can specify other laminates – call to inquire and get a quote.



### Suggested Standard Laminates:



ASIAN NIGHT  
7949-60



BOARDWALK OAK  
7983-60



PEWTER MESH  
4878-60



CLASSIC LINEN  
4943-60



HIGH RISE  
4996-60



BUKA BARK  
7982-60



PALISADES OAK  
7987-60



FLAX LINEN  
4990-60



MISSION MAPLE  
7990-60



NEW AGE OAK  
7938-60

### Classic Standard Laminates:



WILD CHERRY  
7054-60



GREY NEBULA  
4622-60



FUSION MAPLE  
7909-60

All 13 of the standard laminates are -60 finish, if you need to match a laminate from a previous year, please let us know on your order (example Pewter Mesh 4878-38, our standard is -60).

When the WilsonArt Laminate code includes a "Y", "K", "-12" "-78", "Aeon" etc, these are special laminates with an upcharge, even when it contains -38 or -60.

## Standard Edge Color Options



APPLE



BLACK



BLUEBERRY



BURGUNDY



CERULEAN



CHAMPAGNE



CHARCOAL



CHOCOLATE



CLEMENTINE



FOREST GREEN



FUCHSIA



MINT



MOCHA



NAVY



ORANGE



PERSIAN BLUE



PLATINUM



PURPLE



RED



YELLOW

# mobile drawer pedestal

model #: 19173

box box file drawer pedestal

**DIMENSIONS & FREIGHT:**

MODEL #	D"	W"	H"	F.C.	WEIGHT
19173	22"	15.5"	23.25"	100	40 lbs
carton	27.5"	21"	29.5"		

**GLIDES** = 23.25" HEIGHT | **CASTERS** = 25.25" HEIGHT

**OVERVIEW:**

Box / Box / File drawer. Key gang lock. Mobile pedestal is easy to maneuver. Doubles as projector stand and can hold table top lectern for student use.

**MATERIALS:**

The body of the cabinet is all welded 20-gauge steel construction. Includes four-wheel rail system for each drawer. File Drawers have integrated rails for standard hanging file folders. Drawers are secured using a gang locking system.

Each mobile pedestal comes with both **adjustable glides** as well as **casters** with brakes. Also a 5th wheel is included to prevent the drawer from tilting when fully extended when using the caster option. Each unit comes with a long-lasting and durable powder coat finish.

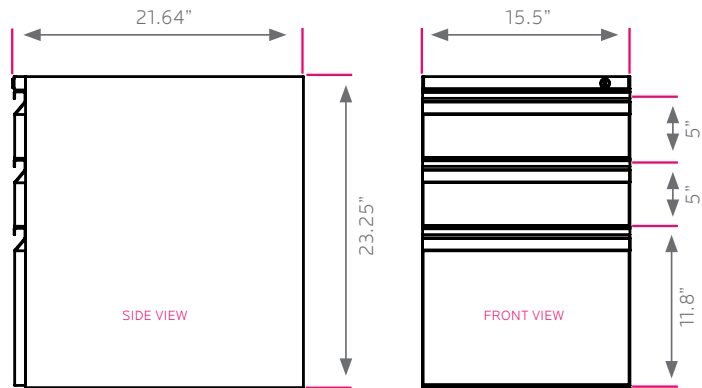

frame **COLORS**



BLACK  
BLA



PLATINUM  
PLT