

cascade 2-sided whiteboard

model #: H10030000PP

2-sided whiteboard

DIMENSIONS + FREIGHT:

MODEL #		D"	W"	H"	F.C.	WEIGHT
H10030000PP	x30 3" totes	21"	43"	70"	100	290 lbs.
H10000140PP	x14 6" totes	21"	43"	70"	100	270 lbs.
	carton	22"	45"	72"	100	40 lbs.

OVERVIEW:

The Cascade series provides storage for a wide variety of items. The 2-sided whiteboard unit is unique in the Cascade lineup, featuring whiteboards on both sides, and 2 columns of tote tray storage.

MATERIALS:

The **END PANELS** are made of 18-gauge 1" square tubing, welded flush to an 18-gauge end panel. The inside of each end panel is reinforced by 22-gauge hat channels. These hat channels are dual purpose: added strength and for tote rail shelf mounting. The dome top is 18-gauge formed and welded construction, bolted to each end panel and rear panel with a total of 10 machine screw fasteners. The base is a durable 18-gauge steel construction formed and welded to support the entire weight of the unit square. Underneath is a heavy welded hat channel reinforcement. The base shelf is attached to both end panels using 4 machine screw fasteners. The Rear Panel is 18-gauge steel reinforced with up to three vertical hat channels. Two grommet holes (a lower and upper) are punched for convenient wire management and electronic storage. Casters are 5" in diameter, with 2 locking. Optional glides are 3/8" threaded stem.



2-sided whiteboard Frame



PLATINUM

***Cascade Two-Sided Whiteboard Unit available in PLATINUM ONLY.**

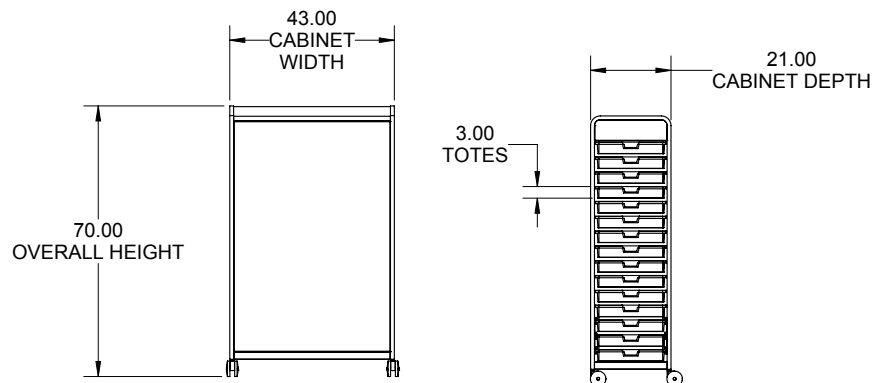

*see catalog for all optional parts & accessories.