



Interchange® Activity Table

Squiggle Table

MODEL#: 04154-04155



OVERVIEW

Our Interchange® Squiggle Table has an elegant curve design that nests with other Squiggle tables to create a collaborative pod. Paired with our Interchange Elipse leg sets, these tables offer a stable work surface for the classroom. Interchange Activity tables match the look and style of Interchange® student desks for a uniform look in the classroom.

MATERIALS

The WORK SURFACE is made of 1 1/4" or 3/4" thick, high density particle board core, double sided with a 0.030" high pressure laminate and bumper edge that is mechanically fastened every 6"-8". Tops are pre-drilled for leg set attachment and ease of installation. Tables and legs are supported by one or more 2" x 3" channels with four breakovers for optimum strength.

The LEG SETS are made in pairs, made of 16 gauge steel elliptical stems and inserts, 14 gauge cross brace and 12 gauge plates. Frame consists of two fully welded segments. Legs have a full, even and long lasting powdercoat finish. Ends are protected with a textured cap and securely captured leveling glide for fine tuning adjustment on uneven floors. Table height adjusts from 22" - 34" in 1" increments. Adjustment for each leg is secured by two 3/8" set screws.

INTERCHANGE® TOP & EDGE PROFILE

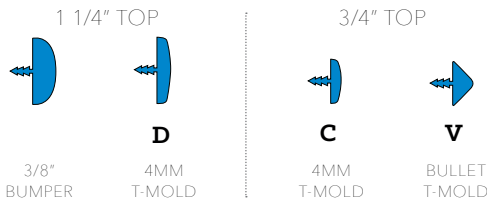

DIMENSIONS

Model	Description	D"	W"	H"	F.C.	Cube	WT
04154	60" Interchange® Squiggle Table	30	60	22-34	70	3.7	106
04155	72" Interchange® Squiggle Table	41	72	22-34	70	5.4	125

60" Interchange® Squiggle Table

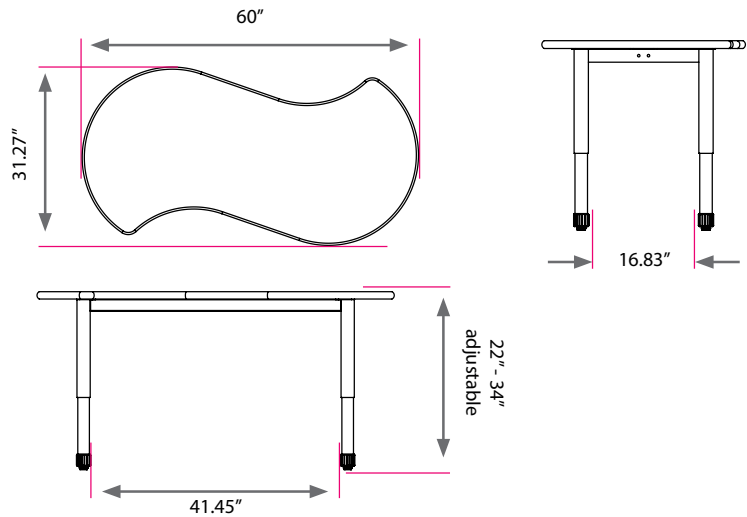

72" Interchange® Squiggle Table

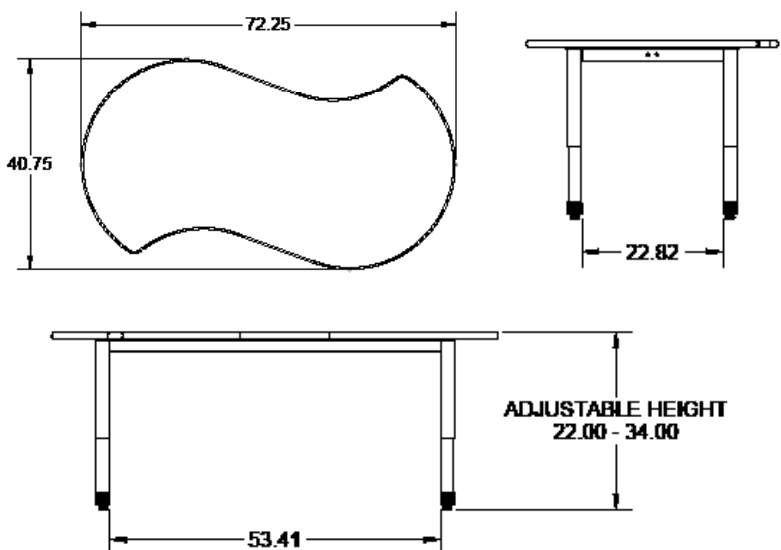

STANDARD LAMINATE OPTIONS

Want to specify a different laminate?

No problem. If you have 20 or more tops of the same color -60 or -38 there is no upcharge. Have 20 or less? We can quote for you with the Wilsonart code and - finish style. We can specify other laminates - call to inquire and get a quote.



SUGGESTED LAMINATE OPTIONS

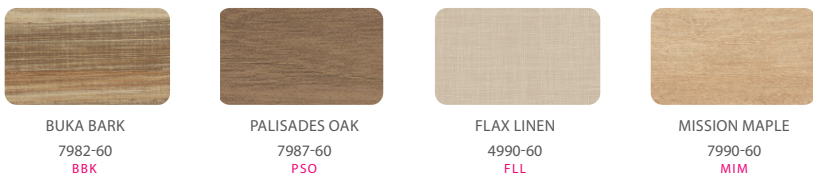

All 15 of the standard laminates are -60 finish, if you need to match a laminate from a previous year, please let us know on your order (example Pewter Mesh 4878-38, our standard is -60).

When the WilsonArt Laminate code includes a "Y", "K", "-12", "-78", "Aeon" etc, these are special laminates with an upcharge, even when it contains -38 or -60.

Classic Standard Laminates:

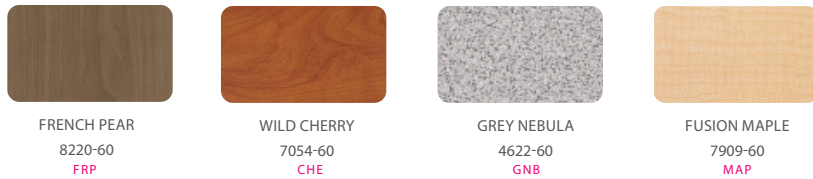

STANDARD EDGE COLOR OPTIONS



LEG COLOR OPTIONS

