



planner lab station

30" x 48" corner station

MODEL #: 24600

PLANNER LAB CORNER STATION

DIMENSIONS + FREIGHT

MODEL #	D"	W"	H"	F.C.	CUBE	WEIGHT
24600	30"	48"	22" - 32"	70	5.8	114 lbs.

OVERVIEW

Planner Lab corner stations allow your computer lab to wrap into the corners of your classroom. The desk is built with Planner™ strength and stability. Manages cables while providing a snug fit against both walls.

The WORK SURFACE consists of a 1 1/4" thick, 45 lb density particle board core with a 0.030" high pressure laminated surface and a 0.020" backer sheet. The edge of the work surface features T-mold that is stapled to the underside of the work surface every 6"-8". The LEG SYSTEM is attached to the pre-drilled holes in the top with (12) #10 x 3/4" screws through a 3 1/8"W x 18"L 14-gauge steel mounting plate. The mounting plate is welded to (2) 1 1/4" square 14-gauge steel tube legs which is welded to a 1" square 14-gauge steel tube cross bar. The leg inserts are 1" square 14-gauge steel tube and adjust in height from 22" to 32" in 1" increments. The adjustment for each leg is secured with (2) 3/8" - 16 x .675" Allen screws. The right and left leg both include the Smith System patented BACKPACK PEG allowing for either inside or outside positioning. The legs are tied together for added strength with a 6" high 18-gauge steel panel and four connector bolts. Legs have 1" adjusting leveling glides. A WIRE BASKET that mounts under the work surface is included for wire management.

PLANNER LAB TOP & EDGE

1 1/4" TOP

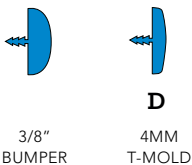

Model 24600 Planner Lab Corner Station in Maple top, Black edge and Platinum frame.

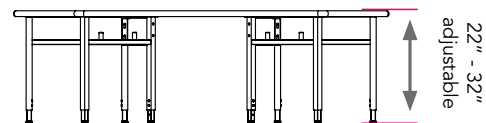
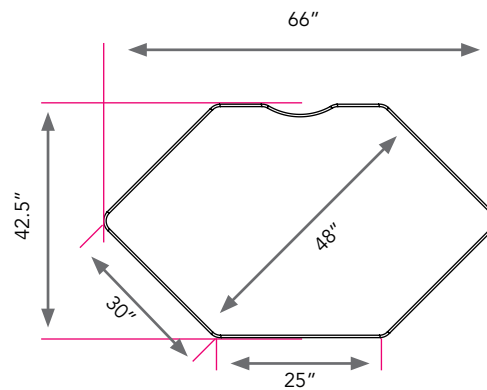

Frame Color Options



BLACK
BLA



PLATINUM
PLT



Optional monitor mount available at additional cost: order Model #17350.

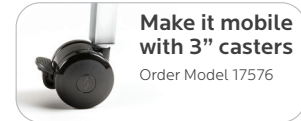

Optional 3" casters available at additional cost: order Model #17576.

Standard Laminate Options

Want to specify a different laminate?

No problem. If you have 20 or more tops of the same color -60 or -38 there is no upcharge. Have 20 or less? We can quote for you with the Wilsonart code and – finish style. We can specify other laminates – call to inquire and get a quote.



Suggested Standard Laminates:



ASIAN NIGHT
7949-60
ANG



BOARDWALK OAK
7983-60
BWK



PEWTER MESH
4878-60
PEW



CLASSIC LINEN
4943-60
CLN



HIGH RISE
4996-60
HRE



BUKA BARK
7982-60
BBK



PALISADES OAK
7987-60
PSO



FLAX LINEN
4990-60
FLL



MISSION MAPLE
7990-60
MIM



NEW AGE OAK
7938-60
NEW

Classic Standard Laminates:

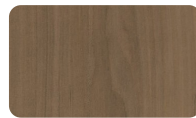

FRENCH PEAR
8220-60
FRP



WILD CHERRY
7054-60
CHE



GREY NEBULA
4622-60
GNB



FUSION MAPLE
7909-60
MAP

All 14 of the standard laminates are -60 finish, if you need to match a laminate from a previous year, please let us know on your order (example Pewter Mesh 4878-38, our standard is -60).

When the WilsonArt Laminate code includes a "Y", "K", "-12" "-78", "Aeon" etc, these are special laminates with an upcharge, even when it contains -38 or -60.

Standard Edge Color Options



APPLE A



BLACK B



BLUEBERRY C



BURGUNDY D



CERULEAN S



CHAMPAGNE O



CHARCOAL R



CHOCOLATE Q



CLEMENTINE E



FOREST GREEN F



FUCHSIA G



MINT H



MOCHA T



NAVY I



ORANGE U



PERSIAN BLUE J



PLATINUM P



PURPLE K



RED L



YELLOW N