



# cascade mega-case with shelves

MODEL #: 31100000P\_

## OVERVIEW

The Cascade series provides storage for a wide variety of items. The Mega-Case is a large width, medium height cabinet in the Cascade grouping, measuring in at 30 7/16" tall, 42 5/8" wide and 19" deep.

## MATERIALS

The END PANELS are made of 18-gauge 1" square tubing, welded flush to an 18-gauge end panel. The inside of each end panel is reinforced by 22-gauge hat channels. These hat channels are dual purpose: added strength and for tote rail shelf mounting. The dome top is 18-gauge formed and welded construction, bolted to each end panel and rear panel with a total of 10 machine screw fasteners. The base is a durable 18-gauge steel construction formed and welded to support the entire weight of the unit squarely. Underneath is a heavy welded hat channel reinforcement. The base shelf is attached to both end panels using 4 machine screw fasteners. The Rear Panel is 18-gauge steel reinforced with up to three vertical hat channels. Two grommet holes (a lower and upper) are punched for convenient wire management and electronic storage. Casters are 4" in diameter, with 2 locking. Optional glides are 3/8" threaded stem.

RISER SHELVES are sized perfectly for each cabinet size. These riser shelves are made of 3/4" high density particle board with your choice of laminate and bullet T-Mold color. Shelf is suspended 6 inches above the dome top with 4 riser shelf handles, which measure 1 1/2" diameter and come in Platinum powder coat paint finish (0.03" Thickness). These riser shelf handles bolt on from underneath the dome top with a hefty 3" washer.

The optional DOORS include a secure and reliable locking mechanism, which engages lock rods into the dome top and the base shelf. Doors also come with urethane ergonomic and modern door handles of your color choice. The fully hinged doors articulate 270 degrees, free of obstruction.

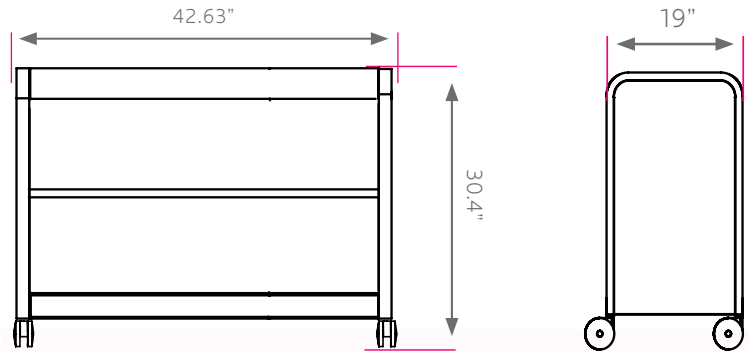

## MEGA-CASE W/ SHELVES

MODEL	DESCRIPTION	D"	W"	H"	F.C.	WT.
<b>Shelves</b>						
31100000P_	Open w/shelves	19	43	30.4	100	82
32100000P_	Doors w/shelves	19	43	30.4	100	96
311100000P_-----	Open w/shelves & riser	19	43	37	100	117
321100000P_-----	Doors w/shelves & riser	19	43	37	100	131
311J00000P_-----	Open w/shelves & lectern	19	43	41.5	100	119
321J00000P_-----	Doors w/shelves & lectern	19	43	41.5	100	133
	pallet dimensions	26	45	32		



# cascade mega-case

## with totes

MODEL #: 310015000P\_

### OVERVIEW

The Cascade series provides storage for a wide variety of items. The Mega-Case is a large width, medium height cabinet in the Cascade grouping, measuring in at 30 7/16" tall, 42 5/8" wide and 19" deep.

### MATERIALS

The END PANELS are made of 18-gauge 1" square tubing, welded flush to an 18-gauge end panel. The inside of each end panel is reinforced by 22-gauge hat channels. These hat channels are dual purpose: added strength and for tote rail shelf mounting. The dome top is 18-gauge formed and welded construction, bolted to each end panel and rear panel with a total of 10 machine screw fasteners. The base is a durable 18-gauge steel construction formed and welded to support the entire weight of the unit squarely. Underneath is a heavy welded hat channel reinforcement. The base shelf is attached to both end panels using 4 machine screw fasteners. The Rear Panel is 18-gauge steel reinforced with up to three vertical hat channels. Two grommet holes (a lower and upper) are punched for convenient wire management and electronic storage. Casters are 4" in diameter, with 2 locking. Optional glides are 3/8" threaded stem.

RISER SHELVES are sized perfectly for each cabinet size. These riser shelves are made of 3/4" high density particle board with your choice of laminate and bullet T-Mold color. Shelf is suspended 6 inches above the dome top with 4 riser shelf handles, which measure 1 1/2" diameter and come in Platinum powder coat paint finish (0.03" Thickness). These riser shelf handles bolt on from underneath the dome top with a hefty 3" washer.

The optional DOORS include a secure and reliable locking mechanism, which engages lock rods into the dome top and the base shelf. Doors also come with urethane ergonomic and modern door handles of your color choice. The fully hinged doors articulate 270 degrees, free of obstruction.



### MEGA-CASE W/ TOTES

MODEL	DESCRIPTION	D"	W"	H"	F.C.	WT.
<b>Standard Width (SW) Totes</b>						
310015000P_	Open w/fifteen 3" SW totes	19	43	30.4	100	90
320015000P_	Doors w/fifteen 3" SW totes	19	43	30.4	100	104
310115000P_-----	Open w/fifteen 3" SW totes & riser	19	43	37	100	115
320115000P_-----	Doors w/fifteen 3" SW totes & riser	19	43	37	100	129
310J15000P_-----	Open w/fifteen 3" SW totes & lectern	19	43	41.5	100	117
320J15000P_-----	Doors w/fifteen 3" SW totes & lectern	19	43	41.5	100	131
310009030P_	Open w/nine 3" & three 6" SW totes	19	43	30.4	100	92
320009030P_	Doors w/nine 3" & three 6" SW totes	19	43	30.4	100	106
310109030P_-----	Open w/nine 3" & three 6" SW totes & riser	19	43	37	100	117
320109030P_-----	Doors w/nine 3" & three 6" SW totes & riser	19	43	37	100	131
310J09030P_-----	Open w/nine 3" & three 6" SW totes & lectern	19	43	41.5	100	119
320J09030P_-----	Doors w/nine 3" & three 6" SW totes & lectern	19	43	41.5	100	133
<b>Extra Wide (EW) Totes</b>						
A10010000P_	Open w/ten 3" EW totes	19	43	30.4	100	92
A20010000P_	Doors w/ten 3" EW totes	19	43	30.4	100	106
A10110000P_-----	Open w/ten 3" EW totes & riser	19	43	37	100	117
A20110000P_-----	Doors w/ten 3" EW totes & riser	19	43	37	100	131
A10J10000P_-----	Open w/ten 3" EW totes & lectern	19	43	41.5	100	119
A20J10000P_-----	Doors w/ten 3" EW totes & lectern	19	43	41.5	100	133
A10006020P_	Open w/six 3" & two 6" EW totes	19	43	30.4	100	92
A20006020P_	Doors w/six 3" & two 6" EW totes	19	43	30.4	100	106
A10106020P_-----	Open w/six 3" & two 6" EW totes & riser	19	43	37	100	117
A20106020P_-----	Doors w/six 3" & two 6" EW totes & riser	19	43	37	100	131
A10J06020P_-----	Open w/six 3" & two 6" EW totes & lectern	19	43	41.5	100	119
A20J06020P_-----	Doors w/six 3" & two 6" EW totes & lectern	19	43	41.5	100	133
	pallet dimensions	26	45	32		

## Cascade Frame



PLATINUM



## Standard Laminate Options \*(Casade Riser Shelves)

Want to specify a different laminate?

No problem. If you have 20 or more tops of the same color -60 or -38 there is no upcharge. Have 20 or less? We can quote for you with the Wilsonart code and – finish style. We can specify other laminates – call to inquire and get a quote.



### Suggested Standard Laminates:



ASIAN NIGHT  
7949-60  
**ANG**



BOARDWALK OAK  
7983-60  
**BWK**



PEWTER MESH  
4878-60  
**PEW**



CLASSIC LINEN  
4943-60  
**CLN**



HIGH RISE  
4996-60  
**HRE**



BUKA BARK  
7982-60  
**BBK**



PALISADES OAK  
7987-60  
**PSO**



FLAX LINEN  
4990-60  
**FLL**



MISSION MAPLE  
7990-60  
**MIM**



NEW AGE OAK  
7938-60  
**NEW**

### Classic Standard Laminates:



WILD CHERRY  
7054-60  
**CHE**



GREY NEBULA  
4622-60  
**GNB**



FUSION MAPLE  
7909-60  
**MAP**

All 13 of the standard laminates are -60 finish, if you need to match a laminate from a previous year, please let us know on your order (example Pewter Mesh 4878-38, our standard is -60).

When the WilsonArt Laminate code includes a "Y", "K", "-12" "-78", "Aeon" etc, these are special laminates with an upcharge, even when it contains -38 or -60.

## Cascade End Panel and Edge Color Options



APPLE **A**



BLACK **B**



BLUEBERRY **C**



BURGUNDY **D**



CERULEAN **S**



CHARCOAL **R**



CHOCOLATE **Q**



CLEMENTINE **E**



FOREST GREEN **F**



FUCHSIA **G**



MINT **H**



MOCHA **T**



NAVY **I**



ORANGE **U**



PERSIAN BLUE **J**



PLATINUM **P**



PURPLE **K**



RED **L**



YELLOW **N**